

CABLE BUS BROCHURE

For over 60 years, MP Husky Cable Bus Systems have been engineered and manufactured for superior reliability. We utilize less constructive material to provide significant savings versus non-segregated phase duct, conduit and wire, and other electrical feeders. As copper prices have continued to remain at historically high levels, the savings clients realize are even greater and more important. No matter how you look at it, MP Husky Cable Bus outperforms other electrical busways in reliability, cost, and flexibility. See for yourself why more owners, engineers, and buyers choose MP Husky Cable Bus systems over the competition.

Introduction

Cable Bus is an electrical busway that consists of an assembly to fully insulated conductors mounted in a ventilated metal housing, utilizing cable support blocks to maintain cable phasing, spacing and short circuit protection. The welded aluminum alloy enclosure is provided in custom lengths, with each piece sized to fit the specific installation. The system includes all necessary equipment connections, flanges, cable, wall entrance seals, fire stops, elbows, offsets, terminal lugs, termination kits, and assembly hardware. A complete set of match-marked layout drawings show the location of each section and accessories, for a simple and fast installation.

Superior Reliability

60 years of engineering, design and manufacturing of Cable Bus systems with installations in nearly every environment, MP Husky Cable Bus is proven and tested to be the most reliable system on the market.

Five key features contributing to superior reliability:

1. High quality cables are continuous from termination to termination, eliminating faulty splices.
2. MP Husky Cable Bus utilizes factory insulated conductors that are designed and manufactured to withstand the harshest outdoor environments. Since our system design is not affected by moisture and is ventilated for indoor and outdoor applications, it does not require heater strips, filter breathers, and thermostats that competitive technologies require, leaving less parts to fail.
3. Each system's phasing arrangement is verified by computer generated inductive reactance calculations to ensure optimal load balance.
4. The system's short circuit capacity is tested to over 100,000 RMS sym. amps. Engineered polymer support blocks provide maximum performance and will not decay, rot or lose structural integrity from exposure to weather, unlike wood or fiberglass.
5. Top and bottom covers are ventilated for optimum cooling of conductors to achieve a free air rating. Actual Heat Rise Tests prove system design.

Lowest Cost

In most electrical applications over 1,000 amps, Cable Bus costs significantly less than non-segregated bus duct cable in tray or conduit and wire systems. As ampacity and/or the cost of copper increases the cost savings of Cable Bus over other systems is even greater.

Since Cable Bus is continuous there are no power losses from intermediate splices or connections. Cable Bus has a lower impedance and lower voltage drop because its conductors are properly phased. Spaced and secured in a pre-engineered system. This reduces operating cost by conductors, combined with our free air rating, allows you to operate fully and efficiently with less conductor than would be called for with other types of systems.

Unmatched Flexibility

MP Husky Cable Bus is easily adjusted to accommodate misplaced equipment and unforeseen obstacles during construction, with little or no delay in the project. Whereas rigid non-segregated phase bus duct must be exact to make equipment terminations, MP Husky provides additional cable and Cable Bus housing to accommodate changes that often occur in the field. If the placement of equipment requires a different bus length, supplemental Cable Bus sections can be quickly adjusted in the field to the required length.

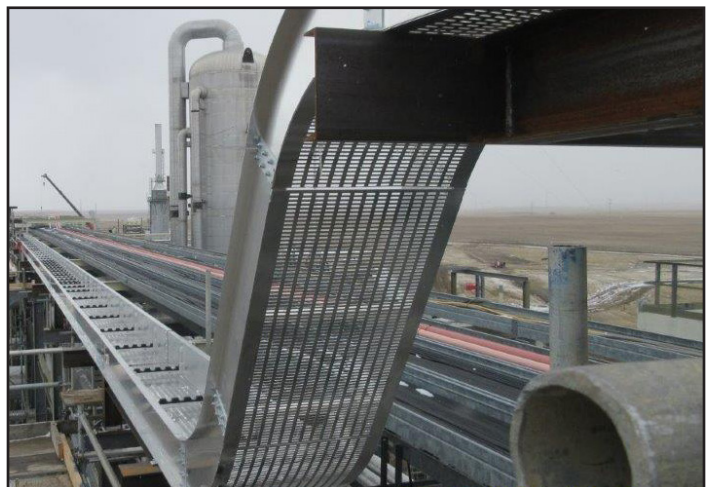

Features & Benefits:

Reliable

- Our system utilized continuous runs of power cable (no faulty splices) from termination to termination.
- MP Husky utilizes high quality, factory tested cables.
- DuraBlock Polymer cable support blocks will not decay, rot or lose structural integrity for 50+ years.

Lowest Cost

- Free Air Rating allows greater ampacity with less conductors, achieving significant cost savings.
- Substantial savings on materials and installation costs compared to other systems.
- In addition to utilizing the least amount of space reduced fittings provide easier, more cost effective and precise connections.

Flexible & Adaptable

- Unlike non-segregated bus duct, MP Husky Cable Bus systems are easily adjusted in the field to accommodate misplaced equipment that often occurs during construction.
- Easily routed around unforeseen field obstructions (i.e. piping, structural steel, equipment, etc.)
- Our extensive custom fabrication capabilities ensure that we can manufacture a system to meet all your difficult coordination challenges.

Free Air Rating for Conductors

- Up to 40% less conductors are needed to carry fully rated current.
- Minimum temperature rise due to ventilated enclosure and maintained cable spacing by custom support blocks.
- Maximum ampacity in accordance with ICEA listings for 90 degree celsius rated conductors.

Indoor or Outdoor Applications

- Utilized for indoor or outdoor applications.
- No special finishes are required with housing utilizing non-corrosive marine grade aluminum.
- Excellent protection against adverse environments including Paper Mills, Fossils, Chemical Plants, Cold, hot and Tropical locations.
- Suitable for food processing and data centers as well.

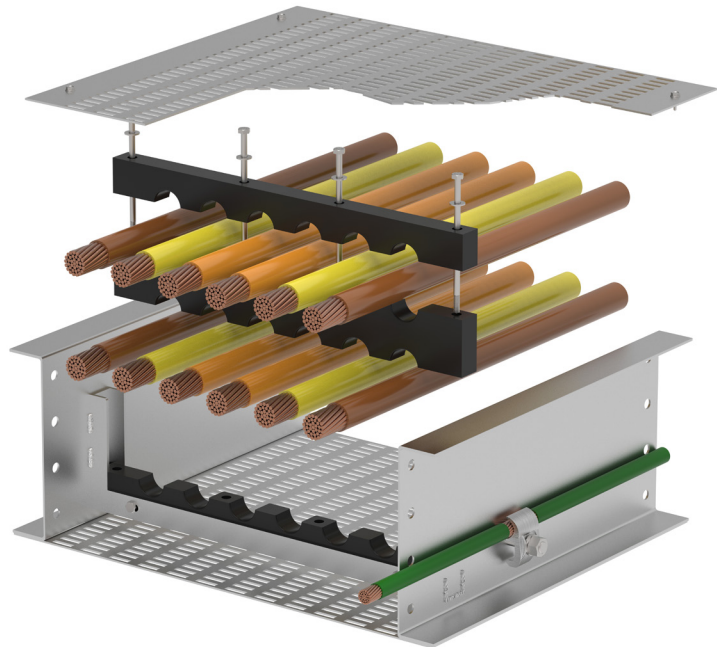

Testing and Certification

- Certified to CSA/ANSI 22.2 #273:19 (Cablebus).
- UL Classified as an equipment ground.
- Actual Heat Rise Tests on widest range of system ratings.
- Actual Short Circuit Test up to 120kA RMS Symmetrical.
- Actual Heat Rise Test verifying MP Husky Cable Bus in trench applications.
- Actual Load Tests confirm structural capability of housing, including up to 20'-0" spans.

Match-Marked Layout Drawings

- Cable Bus system layout drawings are shipped complete with match-marked numbers that correspond to each Cable Bus section.
- Product labels utilize large items numbers to facilitate quick product location and installation.

Features & Benefits:

Labor Savings

- Cables run in parallel throughout entire bus housing.
- Our system does not interleave or transpose cables in the bus housing.
- Lightweight, ventilated enclosure that two people can easily lift 12' or 24' sections into position.
- No special heavy erection equipment required.

Safe

- MP Husky Cable Bus is an all welded rigid construction.
- Contractors are free of shock hazards - no exposed buselements, only insulated conductors used.
- Ventilated design prevents entry of foreign objects.
- Support block design assures proper cable support and complete restraint during short circuit conditions.

Less Support Material

- Design criteria accomplishes high load carrying ability on long spans with minimal support material
- Flush bottom design allows for use of standard support-material.

Complete System

- MP Husky Cable Bus systems are complete with all necessary fittings for direction and elevation changes.
- Termination boxes, equipment flanges, firestops, and wall seals.
- Lugs and termination kits for MV systems.

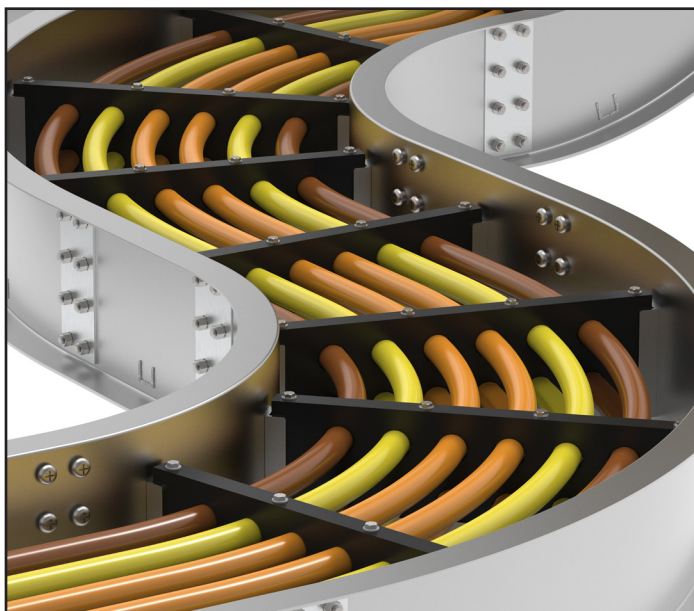

Vertical Bracing System

- Stainless Steel bolts not required during installation.
- Makes vertical and horizontal pulls easier, Thus reducing labor Costs.



Factory Fabricated - All Welded

- Bottom cable support block is factory pre-installed in Cable Bus Housing.
- Entire system is factory fabricated to fit the specific requirements of each individual project.
- All welded constructed for maximum strength.
- All welders are AWS Certified (certified Welding Inspector on site).

Engineering Services

- Experienced all knowledgeable engineering group that can handle difficult coordination challenges.
- Engineering support prior to and during engineering and construction, as well as during and after start-up.

Proper Phase Balance

- MP Husky utilizes an Inductive Reactance Program to achieve the proper cable spacing and phasing arrangement that ensures low impedance and low voltage drop.
- Balanced load carrying of conductors prevents over-heating of cables.
- Cable support blocks provide continuous maintained spacing.

Technical Information:

Selection of the proper Cable Bus system must be undertaken with care to assure that it compliments the design of the overall electrical power system.

Electrical Design

To ensure an efficient, dependable, high quality installation, MP Husky Cable Bus System can be fully engineered with particular emphasis placed on cables, system balance, short circuit capability, and ground requirements. Each one of these key design considerations must be analyzed separately to determine how they affect the overall system design.

Parallel Conductors

Parallel conductors (more than one per phase) can be used to an advantage in Cable Bus where large conductor sizes are encountered. The ampacity per circular mil of conductor decreases as the circular mil or conductor increases. Smaller conductors running parallel are more flexible during installation and have greater current carrying capability than fewer, larger conductors.

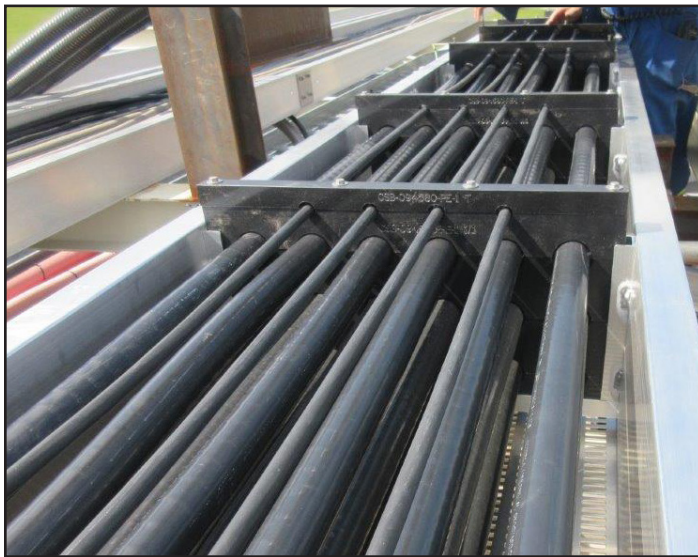

Voltage Drop

Proper system design dictates that voltage drop be considered for both the power feeders separately as well as the entire power system. A voltage drop of 3-4% for power feeders and an overall of 5% or less for the entire system are considered to be within acceptable limits. Cable Bus is designed for low-voltage drop. Voltage drop data is available upon request, for your specific system.

Shielding

Shielding is used on power cables to confine the dielectric field of the conductor to the cable insulation. Shielded Power Cables are used in Cable Bus for applications above 2500 volts and when any of the following conditions exist:

1. Where cable are subject to soot or other heavy deposits that may form paths to ground.
2. Where electrostatic discharge can effect nearby computerized control cables or other low level signals.
3. Concern for personal safety.

When installing shielded cable the metallic shielding must be solidly grounded and the installation must be studied to determine the best grounding method. This is necessary as voltage is induced in the shield of a single conductor cable carrying alternating current due to mutual inductance between its shield and any other conductor in its vicinity. This induced voltage can result in tow conditions:

1. Metal shield bonded or grounded at multiple points creates shield to ground circulating currents. The magnitude of the circulating currents depends on the mutual inductance to the other cables, the current in these conductors, and the resistance of the shield.
2. Shields bonded or grounded at only one point will have a voltage build up in the sheath but will eliminate circulating currents.

The length of the circuit and the load conditions will indicate which of the above shielding methods is required for any particular reason. MP Husky's engineers can provide shield voltage calculations to aid the client in choosing the best grounding method.

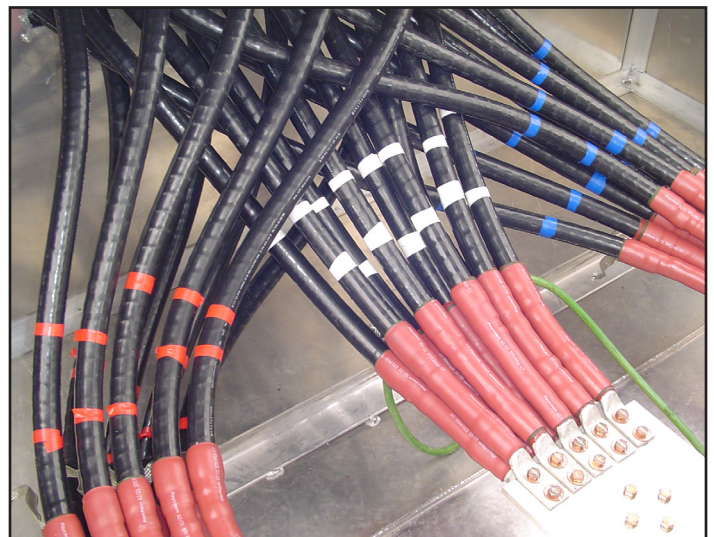

Technical Information:

System Balance

Cable Bus is power distribution system using insulated using conductor power cables with support blocks that maintain cable spacing. Each phase consists of one or more cables connected in parallel. The complete assembly is enclosed in a ventilated aluminum enclosure for support and protection.

Parallel conductor transmission lines, using widely spaced conductors have been in use for many years. The electrical coupling between the conductors of a parallel conductor system, which is a function of the geometry of the location of the conductors, can cause an imbalance in the conductor currents. In a widely spaced overhead transmission line transposition of conductors can economically be used to balance the conductor currents.

The spacing of the conductors in Cable Bus is one cable diameter, (i.e. one to three inches), as compared to the typical value of thirty feet used in overhead lines. This close spacing and the relatively short lengths, as compared to hundreds of miles for overhead lines, make the transposition of conductors within the bus housing a difficult challenge and sometimes practically impossible.



The objective of the Cable Bus design is to obtain the optimum balance for an electrical circuit using parallel conductors (no transposition) with close spacing. MP Husky has developed an Inductive Reactance Program which solves for the line and phase currents of a parallel conductor system using a mathematical model of the transmission line parameters. Through the use of computer programs and verification by laboratory and field testing, MP Husky has designed Cable Bus Systems with minimal imbalance.

MP Husky Cable Bus is designed for balance of conductors within a phase (intra-phase) and balance between the phases (inter-phase). Many phasing arrangements will provide inter-phase balance of currents due to the load impedance, but the majority of these phasing arrangements provide intra-phase current imbalance.

MP Husky's Cable Bus design provides a phasing arrangement that achieves inter-phase current balance, as well as intra-phase current balance, therefore reducing the amount of parallel conductor imbalance to a minimum.



Short Circuit Capacity

A Cable Bus system must be able to withstand the dangerous mechanical forces created by short circuit currents. These forces are transmitted from the conductors to the cable supports. In the case of Cable Bus, the support elements include the support blocks and enclosure.

Short circuit currents are made up of two parts; a symmetrical AC component and a rapidly decreasing DC component, (Fig. 5 on next page) A Cable Bus system must be selected so that its mechanical strength will withstand the maximum instantaneous current and to a lesser degree the 5-8 cycle resultant symmetrical current. The symmetrical current is the actual value that a high voltage breaker will interrupt.

Technical Information:

Since Cable Bus is often used for main feeder connections, (e.g. substation, generator or transformer to switchgear, load centers and high voltage machines), the available short circuit current will be that of the utility or generator supply through the transformers. In some cases the Cable Bus feeds large motors and the motor contribution to short circuit must also be considered. Numerous tables are available listing motor contributions for various operating conditions.

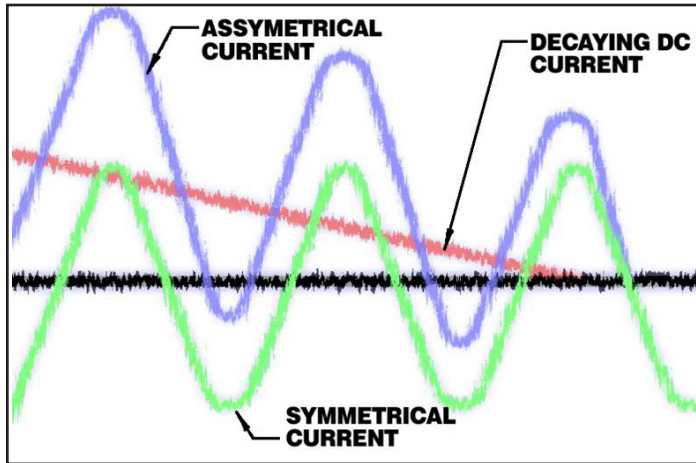

Fig. 5

Available fault currents can be limited to some extent by conductor impedance. The impedance can be in the form of either conductor length, size or a combination of both.

The MP Husky Cable Bus design ignores these added conductor impedance; instead the worst fault conditions are always assumed. For design consideration a three phase short circuit current will result in the maximum mechanical forces for design considerations.

If Cable Bus is fed directly from the utility company service then short circuit current data will be available from the utility.

Where motor contributions are considered, the fault current due to the motor feedback will be a function of the voltage and is usually expressed as multiples of the motor full load current. NEMA standards are available which list these factors. Certified tests have been conducted to determine the short circuit performance of Cable Bus using various supporting arrangements.

Short Circuit Testing

The Cable Bus systems were tested on a 600 volt, 3 phase, 60Hz circuit having a power factor of less than 0.20. One end of the Cable Bus was connected to the source terminals and the other was short circuited to create a three phase bolted fault.

Each test was conducted for a minimum of six cycles. Oscillograms recorded the phase currents during the test. Still photographs and high speed color motion pictures were taken relevant to the test.

MP Husky Cable bus has been subjected to currents of 39,000, 67,500, 85,000, 100,000, 120,000, 125,000, 150,000, 175,000, and 200,000 RMS symmetrical amperes with asymmetrical currents greater than 200,000 amperes. Cable Bus withstood the mechanical forces of the test without any damage to the cables, support blocks or enclosure.



MP Husky 4000Amp, 5kV Cable Bus System with open air termination to GSU transformer.

Technical Information:

Grounding

A Cable Bus system must afford protection to life and property against faults caused by electrical disturbances. Lightning, electrical system failures, as well as failures in the system connected equipment all constitute possible fault hazard locations.

For this reason, all metal enclosures of the system, as well as non-current carrying or neutral conductors should be tied together and reduced to a common potential. This includes the structural steel of the building, water, steam and gas piping.

There are two distinct divisions to the system and equipment grounding problem. The system ground is the connection of the distribution system to earth by means of a neutral or grounded conductor and system grounding serves to limit the voltage, which might appear on the circuit due to lightning or accidental contact.

Cable Bus systems should be grounded to the substation structure and thus to the substation ground grid and to the building steel by means of the Cable Bus support materials. Cable Bus should also be grounded to the equipment or switchgear enclosure.

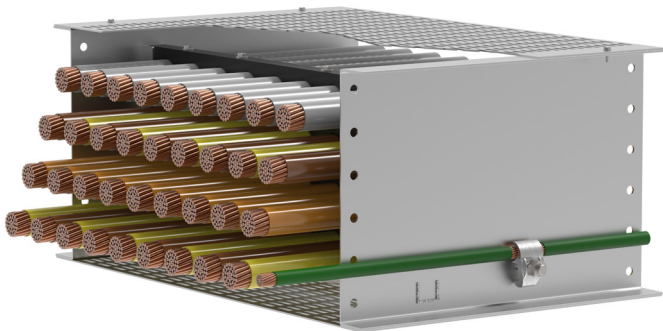

It is an accepted fact that ground currents tend to concentrate near power conductors and that cable enclosures take a large portion of the ground currents; therefore, it is important to consider Cable Bus as a major carrier of ground currents.

MP Husky's Cable Bus enclosure is rated to carry 2000A ground current. Extra ground current capacity can be provided by the application of external ground conductors bonded to each section of Cable Bus housing.

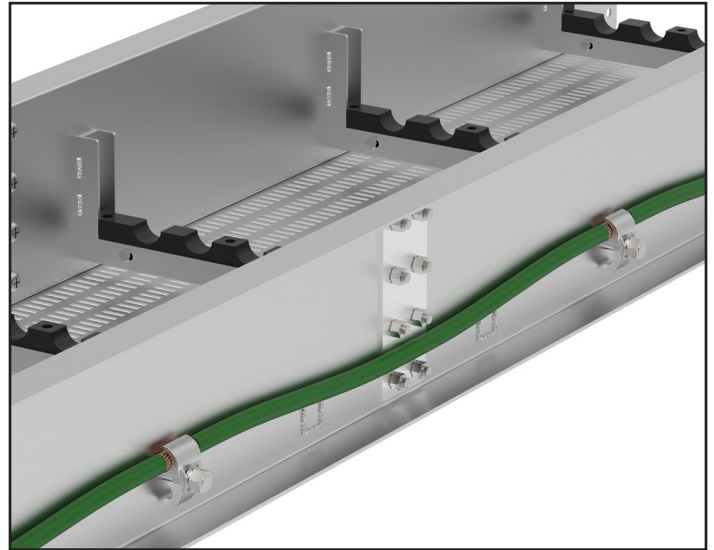

Flexibility

MP Husky Cable bus systems are flexible and adaptable to the many unexpected circumstances that occur during construction. Every size and rating of Cable Bus provided is supplied with up to 5% extra cable as well as one spare length of housing including cover, cable support blocks and hardware. This enables the installer to adjust our system in the field to unexpected changes or field obstructions with little or no delay of the project. And our compact design and radius bends allow our system to maneuver around and fit in tight clearance applications.

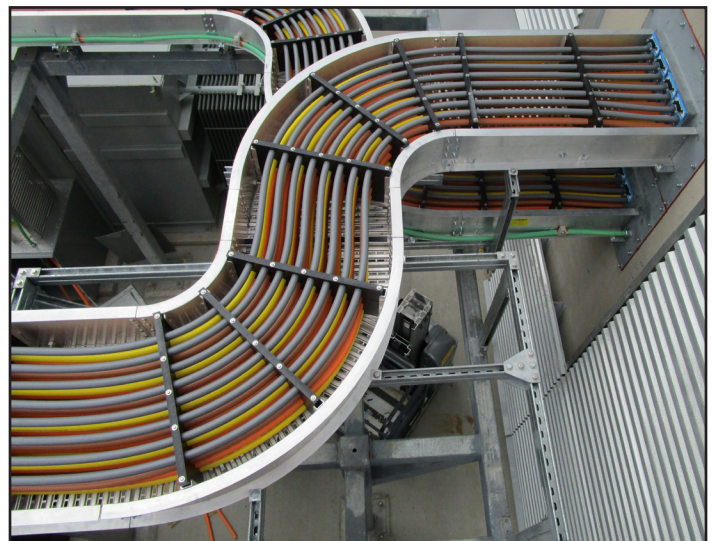

Quality Assurance:

Our Quality Policy

At MP Husky we are committed to producing only the highest quality products that need or exceed our customers expectations and requirements. Our goal is to achieve 100% customer satisfaction by delivering the best products and services on time and defect free. We will achieve this individually and corporately through tested and proven processes and controls, in our Quality System, and with a constant focus and effort on continuous improvement.



MP Husky's Cable Bus System are certified to CSA/ANSI C22.2 #273:19 (Cablebus) and UL Classified as an Equipment Ground.



Item	Standards
MP Husky Quality Program	<ul style="list-style-type: none"> ANSI/ASQC Q9001-2000 (ISO 9001 Compliant) ASME NQA-A-2004 ANSI N45.2
Cable Manufacturers: General Cable, Okonite, Kerite, Prysmian, & others <ul style="list-style-type: none"> Quality Assurance Manufacturing Standards 	ISO 9001 Includes ICEA, CSA, ANSI, IEEE
Certification	<ul style="list-style-type: none"> CSA/ANSI C22.2 No. 273:19 (Cablebus) CSA Certified to C22.2 No. 126.1-02 For Enclosed Grounding UL Classified for Grounding
Load Test Standards	NEMA VE-1/CSA Tray Standards
Cable Bus Support Standard	NEMA VE-2, NEMA CB 15001
Heat Rise Standards	ANSI C37.20, C37.24
Cable Ampacity Standards	<ul style="list-style-type: none"> IPCEA P-46-426; ICEA S-66-524; IEEE S-135 CSA CEC Part 1 & C22.2 United States NEC
Fault Bracing Standards	CSA/ANSI C22.2 NO. 273-1:19
Short Circuit Certification	Eaton High Power Test Labs
Grounding	UL, CSA, NEC
Welding	<ul style="list-style-type: none"> AWS D1.1 (American Welding Society Structural Welding Code: Steel) AWS D1.3/D1.2 (American Welding Society Structural Welding Code: Aluminum) AWS C1.1/ANSI American Welding Society Recommended Practices for Resistance Welding ASME QW 100.1 American Society of Mechanical Engineers Welding Procedure Specifications (Procedure Qualifications Record) Certified Welding Inspector - QC1-96 (On Staff) 100% of MP Husky welders are AWS Certified.

~~BLANK SPACE~~

ANY SUGGESTIONS
ON WHAT TO PUT
HERE?



Customer Testimonials:

“Simply stated, your product is our first choice for new and/or service entrance upgrades. We have been involved in way too many bus duct failures. When given a choice by our customers, we will always try to use MP Husky Cable Bus.”

-Industrial Electrical Contractor

“We have used MP Husky Cable Bus for numerous installations at our facilities. It is the obvious choice for us because first of all, a wall penetration that is off by a few inches or a transformer or switchgear that is off by a few inches, MP Husky Cable Bus can easily accommodate such changes whereas with bus duct, you have to be perfect. Secondly, MP Husky Cable Bus is more cost effective due to the obvious cost advantages in the system which include: no derating of the cables, thus you utilize less copper, lower losses due to proper phasing arrangement of conductors, and the ease of installation.”

-Owner/Engineer

Voltage Ratings:

MP Husky Cable Bus Typical Voltage & Current Ratings												
35kV												
25kV												
15kV												
5kV												
600V												
	800A	1200A	1600A	2000A	2500A	3000A	3500A	4000A	5000A	6000A	7000A	

	Definite Cost Savings on these available Ratings
	Possibly Available or Economical, Consult Factory
	Typically Outside Practical or Economical Range

MP Husky Cable Bus Features:

- Engineered System with Inductive Reactance Program; results for average phase impedance available upon request for the design engineer.
- High fault capacity. Cable Bus is tested up to 200kA RMS Symmetrical.
- Lowest installation cost of any cable bus duct on the market, with the industry exclusive straight cable rungs. No cable transpositions within the housing, regardless of run length. Installation savings of 10% to 25%, depending on run length and cable size.
- Widest available range of Voltage Class and Ampere Ratings in the industry.
- CSA/ANSI C22.2 No. 273:19.
- UL Classified as an equipment ground.



System Componets:

Indoor Connection Flanges:

Indoor connection flanges are used to connect the cable bus housing to indoor electrical equipment (switchgear, motor control center, etc.)

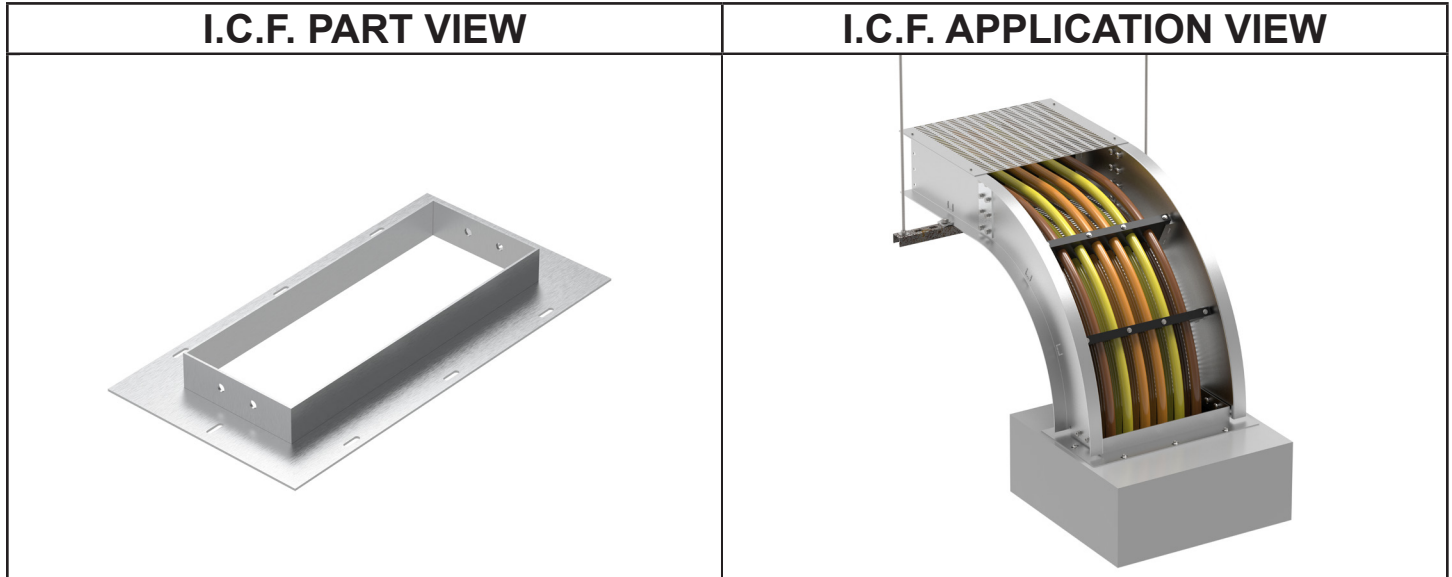

Flexible Boots:

Flexible Boots are used to connect onto walls or any equipment where vibration, or slight movement is of concern. Flexible Boots can be engineered with Indoor Connection Flanges or Environmental Seals on the Cable Bus connection side.

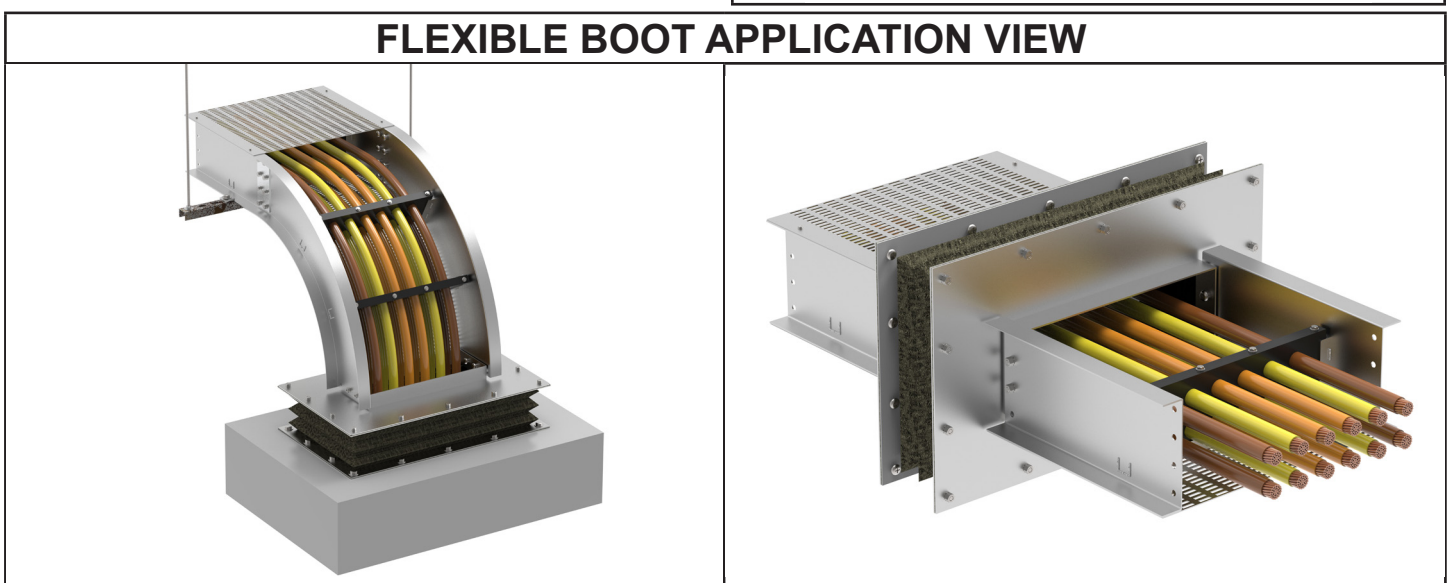
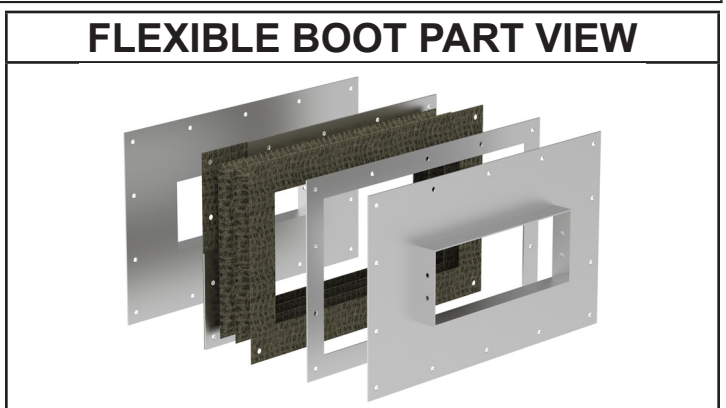

System Components:

Compression Seal Flanges:

Compression seals are used when a watertight seal is required, but no fire rating is needed. Neoprene modules are inserted after the cables are installed for a water-tight seal and ease of pulling.

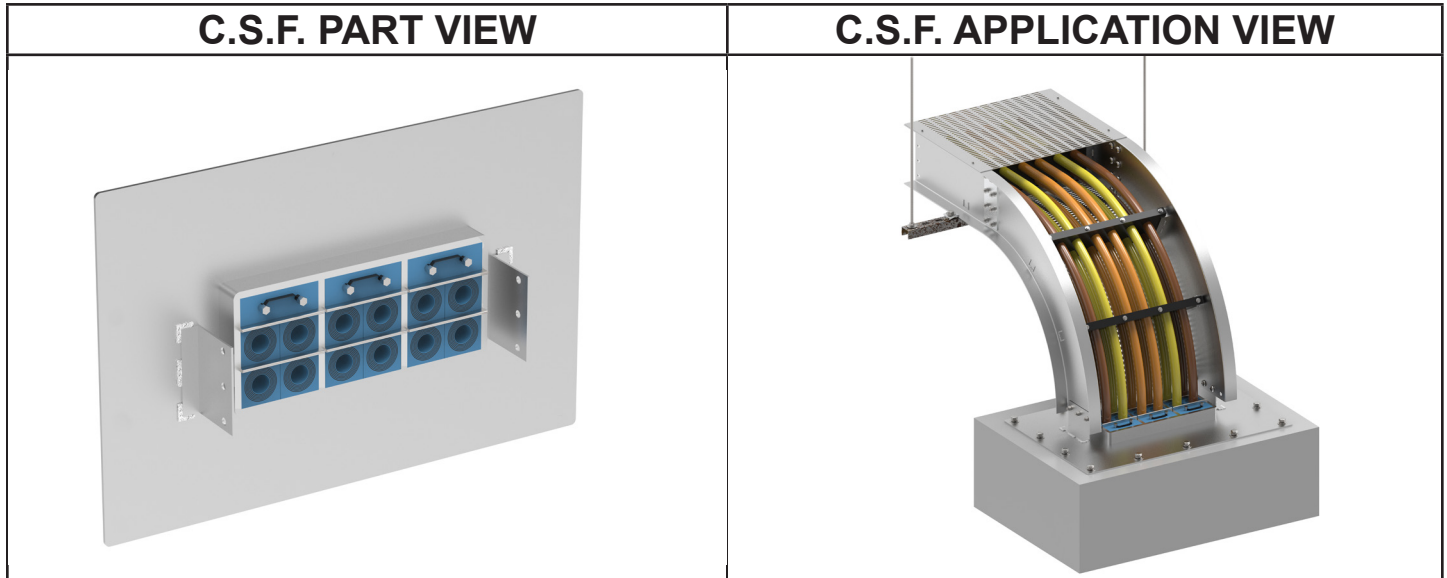

Firestops:

Fire rated MCT seals are used when a fire rated and watertight seal is required. Neoprene modules are inserted after the cables are installed for ease of pulling. They carry a 2 hour fire rating and come with all necessary hardware.

Neoprene modules for use with Roxtec frames. Provide Multidiameter™, the Roxtec technology based on removable layers, for perfect adaptation to a cable.

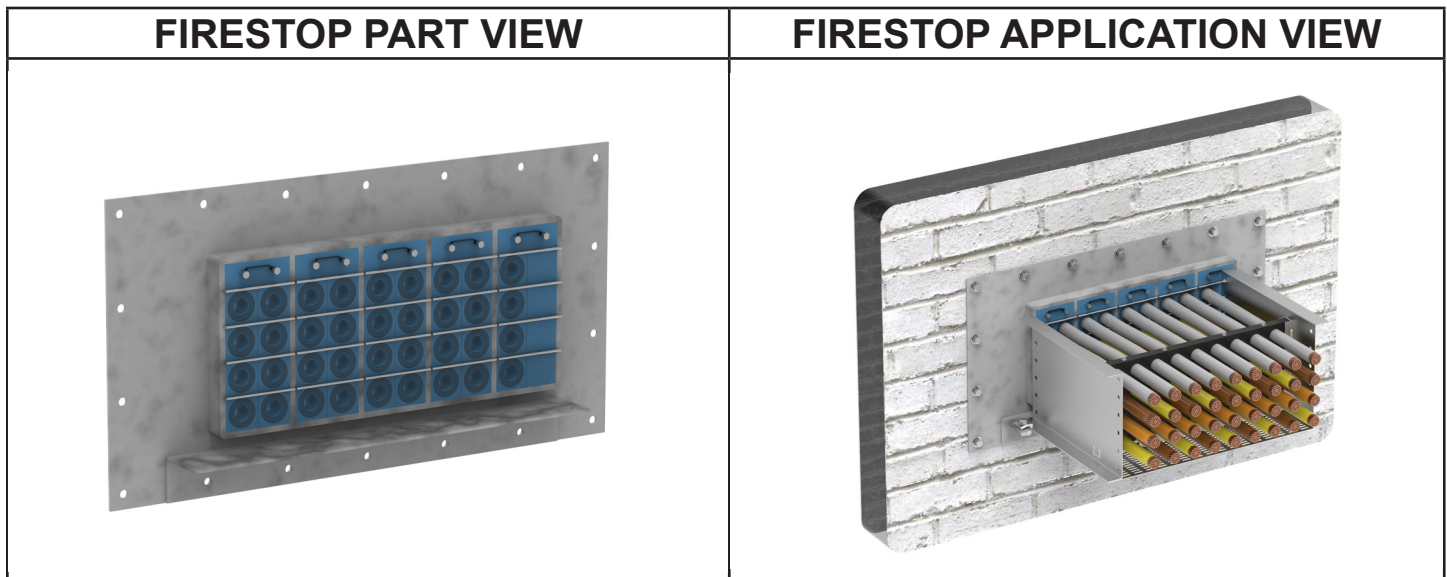
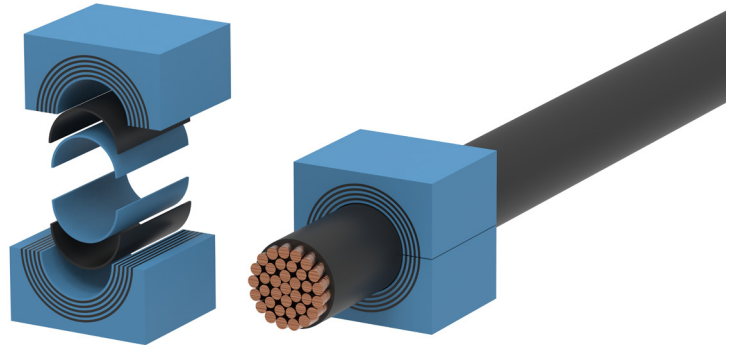

System Componets:

Termination Boxes:

Transformer termination boxes, switchgear/MCC top hats, and other junction boxes designed and supplied by MP Husky guarantee the needed space to properly transpose the phases and terminate the conductors to the electrical equipment. Standard termination boxes are aluminum welded angle frame construction with bolted, removable side panels and welded fixed panels as needed. Outdoor boxes use gasketed removable panels, fully seam welded fixed panels, and an ESF type seal to ensure a weatherproof enclosure.

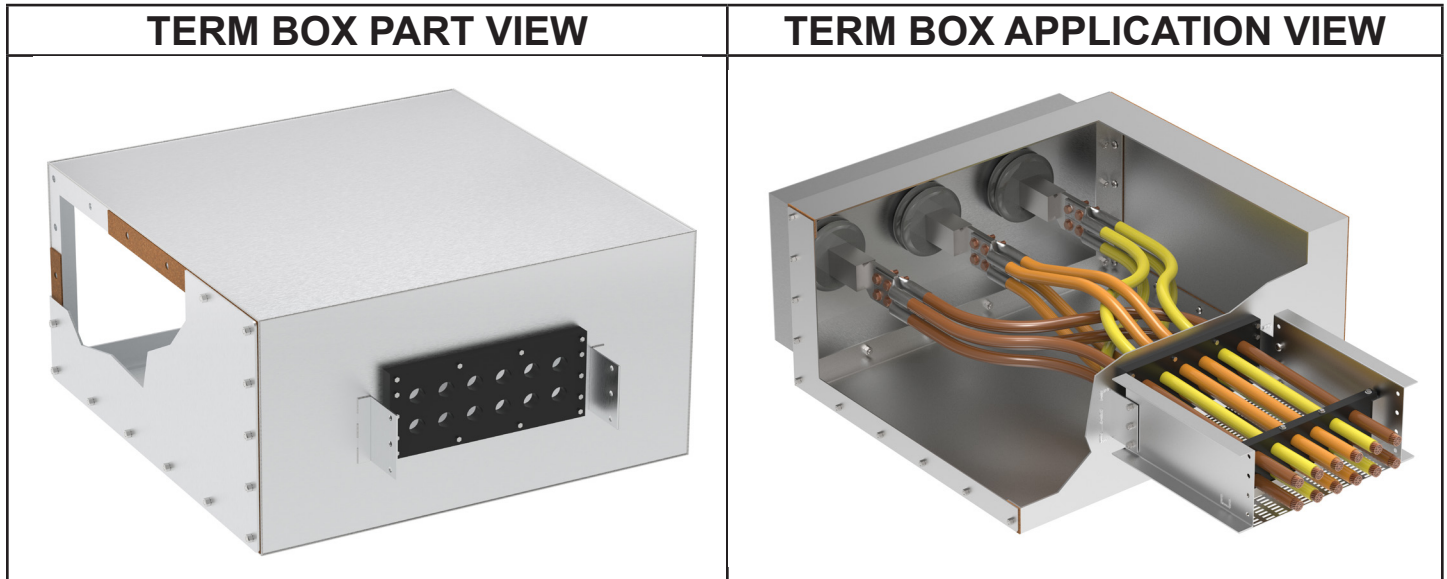

Environmental Seal Flanges:

These fittings form a weatherproof seal with equipment/walls and can also be used for floor penetrations. Conductors are sealed with RTV silicone sealant. Entrance fittings are furnished with all necessary hardware.

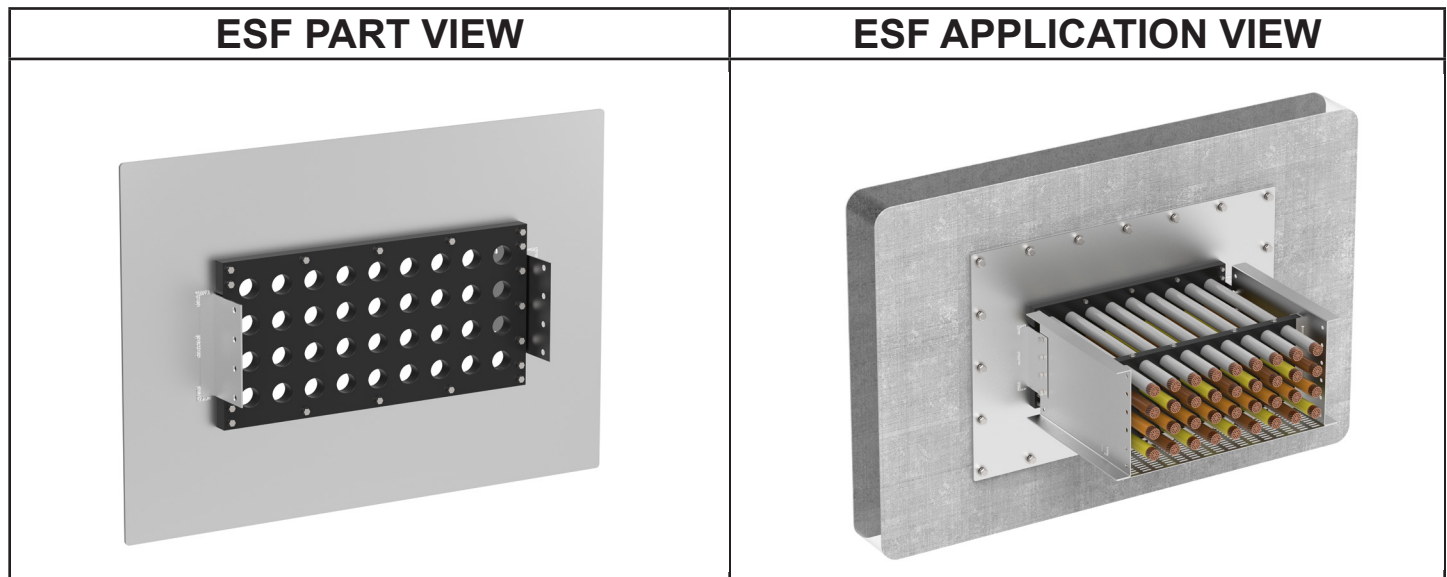

Design Requirements:

In order for MP Husky to proceed with the design of your cable bus system, the following drawings and information need to be submitted:

1. Drawings & submissions, special requirements - engineer will provide any special client title block data electronically to MP Husky and MP Husky will add to the drawings.
2. Equipment layouts, plan and elevation, tied to coordinate points, column lines, or site survey lines.
3. Certified equipment drawings, showing location of termination points and available termination space, as follows:

Transformers	<ul style="list-style-type: none"> • Plan and elevation DWGs with centerlines • Location of the bushing and throat flange relative to the XMFR base and centerlines. • Transformer height from the base to top of cover mounted bushing. • Horizontal distance from XMFR centerline to bushing centerline of cover mounted bushing. • XMFR height from base to horizontal centerline of sidewall mounted bushing. • Horizontal distance from XMFR centerline to bushing extension of sidewall mounted bushing. • Bushing drilling pattern and hole spacing.
Switchgears	<ul style="list-style-type: none"> • Plan and elevation outline DWGs with centerlines. • Side section DWGs showing cable termination space. • Location of the bus bars relative to the switchgear base and centerlines. • Bus bar drilling pattern and hole spacing. • Location (e.g. bottom, top, or side) and size of the entry into the switchgear.
Buildings	<ul style="list-style-type: none"> • Plan and elevation outline DWGs with centerlines. • Outer wall location, construction details, entry locations, and fire ratings. • Dimensioned plan, elevation, and section views showing bus entry locations. • Room elevation above grade. • Equipment layouts referenced against coordinate points, column lines, or site survey grid. • If cable bus entry is below, through the building floor, the following issues may apply: <ul style="list-style-type: none"> » Time Rating of Fire Barriers. » Floor construction details » Method for fire barrier » Mouting directly to the underside of the floor or a throat to which a barrier can be attached.

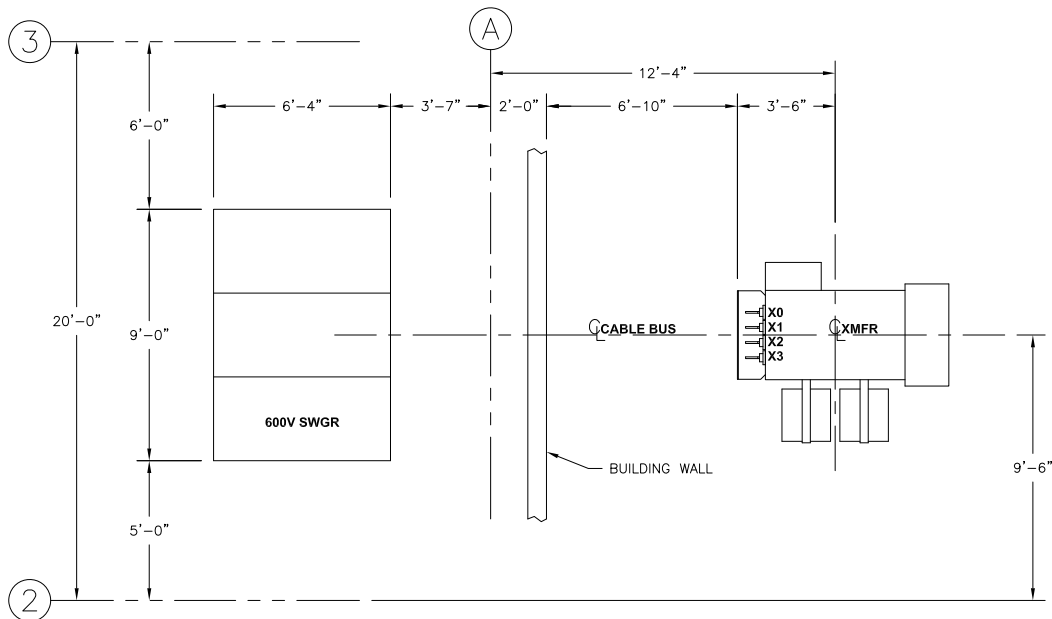

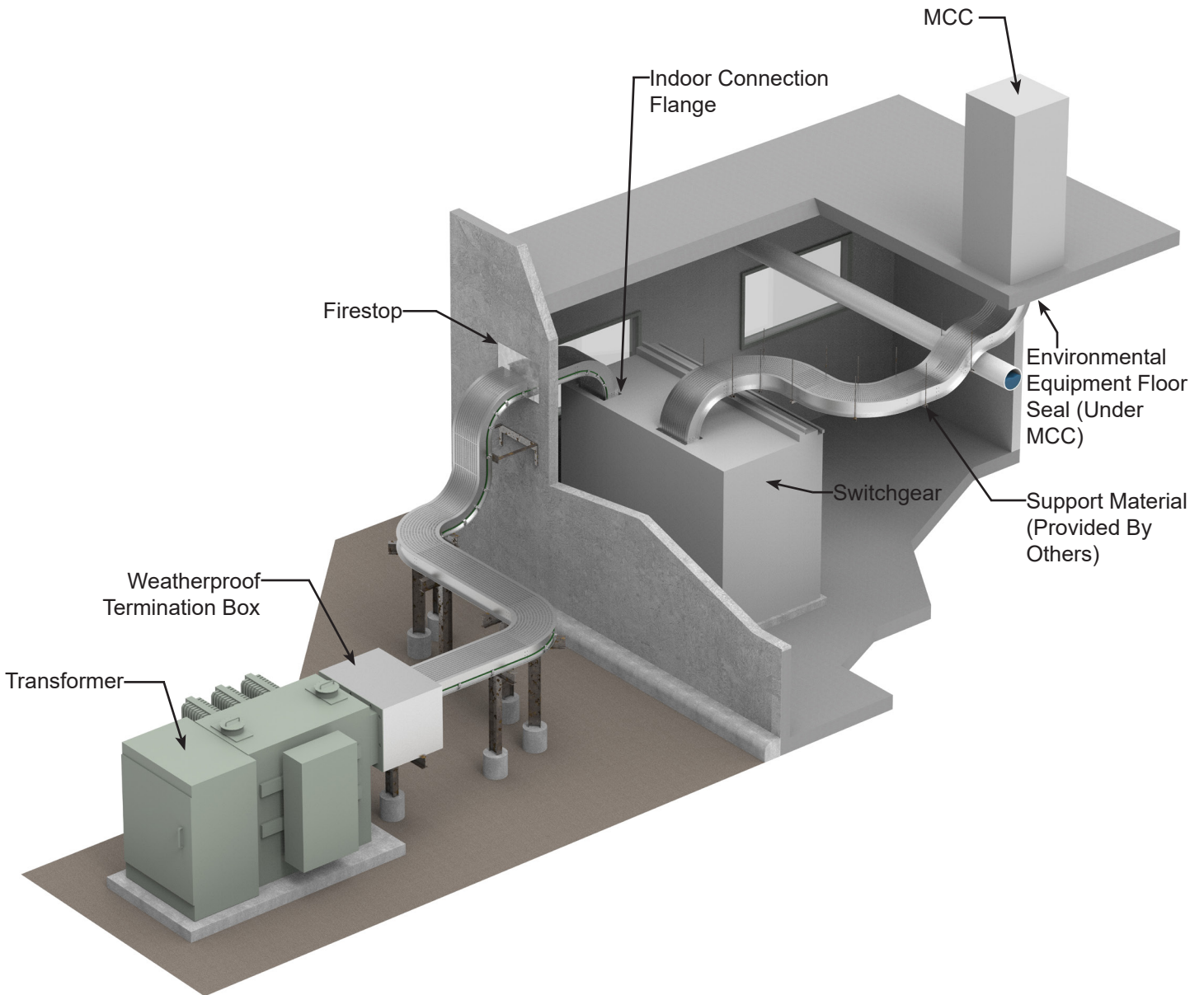

Typical Specification:

1.0 General

- 1.1 A complete metal enclosed bus system shall be provided; including all necessary fittings, enclosure connectors, entrance fittings, insulated conductors, electrical connectors, terminating kits, and other accessories as required.
- 1.2 The bus system shall be suitable for indoor or outdoor use with conductor spacing and ventilation maintained throughout the system.
- 1.3 All elements of the bus enclosure shall be so designed as to eliminate any sharp edges or projections that may injure personal or conductor insulations.
- 1.4 The bus system shall be Cable Bus, as manufactured by MP Husky.

2.0 Construction

- 2.1 All load carrying members of the bus system shall be fabricated from extrusions of aluminum alloy 6063-T6. The maximum allowable stress used in designed shall be 10,000 PSI.
- 2.2 Bus enclosure fittings shall be in accordance with the minimum bending radius of the conductor requires a larger fitting radius.
- 2.3 The top and bottom enclosure sections shall be of flat design to provide mechanical strength and slotted for ventilation. The top cover shall be fastened to the enclosure with self tapping screws spaced approximately 2 feet on centers and shall be removed for inspection. The bottom section shall be factory installed by welding.
- 2.4 Splice joints between sections of the bus enclosure shall be the high pressure splined bolted type of a design which avoids any structural weakness at the connection and does not exceed the electrical resistance specified under Section 3.4 of this specification.
- 2.5 Conductor support blocks shall be designed in segments to maintain the minimum of one conductor diameter in both the horizontal and vertical planes, as required for free air conductor rating. Horizontal runs will have blocks spaced every 36" and vertical runs every 18". Conductor support blocks shall be made of industrial polymer.

3.0 Electrical

- 3.1 All current carrying conductors shall have insulation rated for 90°C operating temperature in accordance with ICEA publication #P-46-426 and interim STD #18#2 to ICEA publication #S-66-524 for the ampacity and voltage specified.
- 3.2 The conductors shall be phased and supported to maintain low impedance and assure the mechanical strength necessary to prevent cable movement or damage under short circuit currents up to 100,000 RMS symmetrical amps.
Conductors shall be of continuous length and be pulled in after the bus enclosure is in place.
- 3.3 Electrical connectors shall be used only at the termination of conductor runs. All electrical connectors shall be provided by MP Husky.
- 3.4 The bus enclosure shall have a continuous current rating of not less than 1,000 amperes (50°C Rise) and the resistance across the enclosure section splice shall not exceed 50 microhms.
- 3.5 The bus enclosure shall be grounded at sufficient intervals for the purpose of preventing a potential above ground on the bus enclosure in the event of a fault.
- 3.6 The conductors shall be arranged in a phasing pattern which exhibits minimal inter-phase and intra-phase imbalance.
- 3.7 Conductor temperature rise and current balance data can be provided in support of Section 3.6 of this specification.
- 3.8 All transposing of cables must occur at termination points. Transposing of cables will not be done in the bus housing.

Quote Form:

The following form can be used to obtain an estimate/quote. Forward to Cable Bus Department, 1370 Old Stage Road, Simpsonville SC, 29681. E-Mail to MPHusky@MPHusky.com.

Bid Due Date: _____

Anticipated PO Date: _____

Customer Information:

Name: _____

Phone Number: _____

E-Mail: _____

Company: _____

Project Information:

Project Name: _____

Project Location: _____

Engineering Firm: _____

Required Delivery Date: _____

System Information:

Voltage			
600V	5kV	15kV	Other

Grounding Requirements
Housing has 2000A UL Listed Grounding Capacity

Neutral			
None	100%	50%	Other

Ampacity	
----------	--

Ambient Temp (if not 40°C)	
----------------------------	--

Cable Information:

Conductor	
Copper	Aluminum

Low Voltage Cable		
XHHW-2	RHH/RHW-USE-2	OTHER

Medium Voltage Cable					
Insulation		Jacket			Other
EPR	XLPE	PVC	CPE	LSZH	

Housing Information & Bill of Material:

Horz Footage	Vert Footage

Aluminum	Anodized	304SS	HDGAF	Other

Elbows		
	Horizontal	Vertical
90°		
60°		
45°		
30°		
15°		

Accessories	
Environmental Wall Seal	
Fire Stop	
Pull Box/Transition Box	
Indoor Connection Flange	
Environmental Equipment Seal	
Termination Box @ Equip. End	

Special Requirements:

Radius For Elbows	
-------------------	--