

Husky Centray

Center Supported Cable Tray

Technical Information	Pg. 191
Advantages	Pgs. 192-193
Introduction to Husky Centray	Pgs. 194-195
Ordering Information	Pgs. 196-199
Connectors & Couplings	Pgs. 200-201
Accessories/Covers	Pgs. 202-205

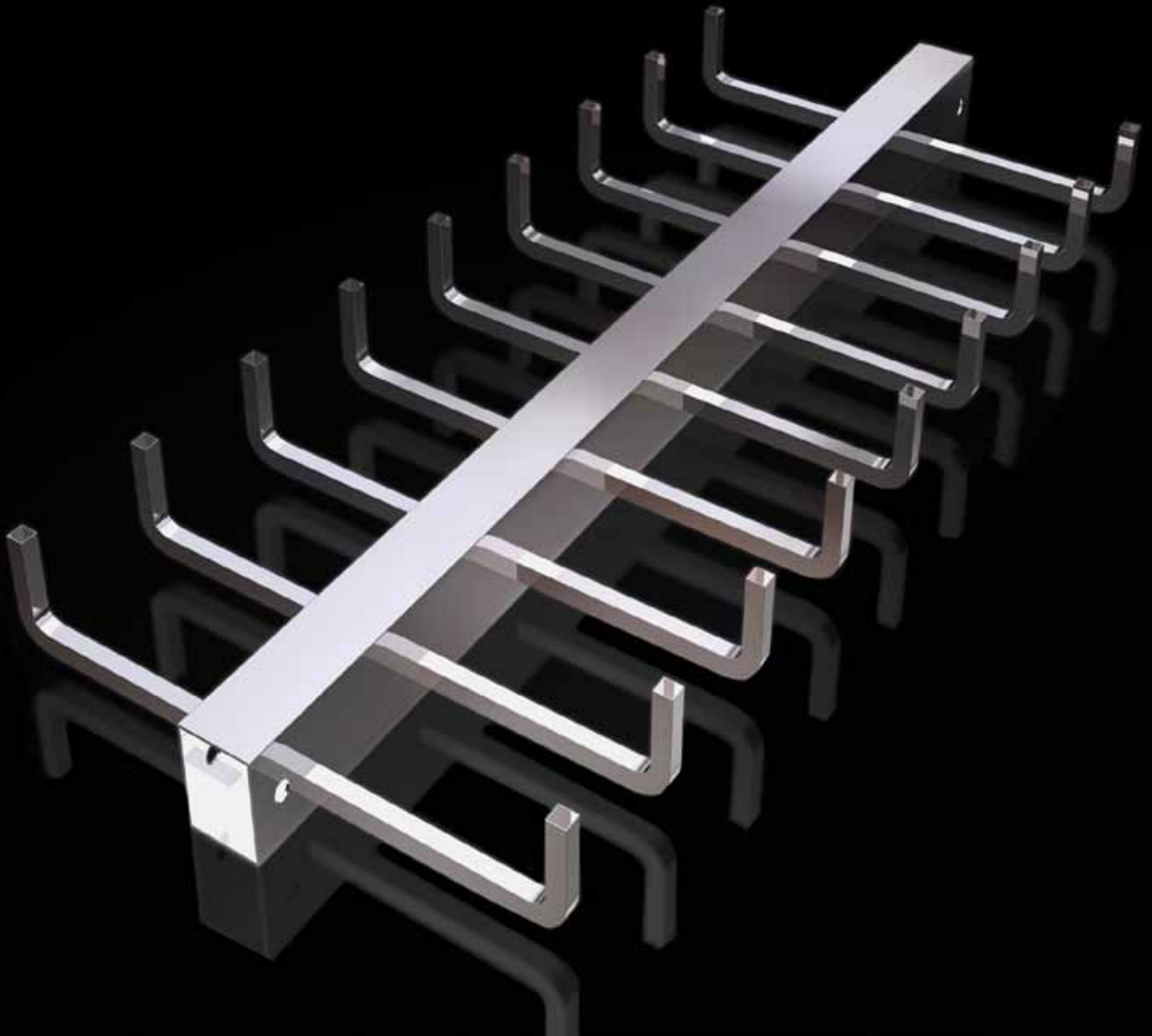

Technical Information

HUSKY CENTRAY—CENTER HUNG AND WALL MOUNT CABLE TRAYS

Material: The spine and the rungs are manufactured from 6063-T6 high strength aluminum. The spine is 3" high and 1-1/2" wide. The rungs is 1/2" wide and 1/2" high.

Construction: The spine is punched on top or bottom to accept the insertion of rungs. The rungs are inserted through the spine and fastened by a four point high pressure staking operation that secures the rung in two locations on each side of the spine. The staking operation holds the rungs in place preventing loose rungs. The ends of the rungs are then bent upward to the desired fill depth (3", 4" or 6"), measured from the cable support surface to the top of the rung. The rung tips are rounded to prevent sharp edges.

Accessories: Each tray is supplied with a splice/hanger connector that is used to fasten the tray sections together and can also be used to hang the tray from 1/2" diameter hanger rods. The splice/hanger connectors are rectangular in shape and fit inside the tray spine and are secured with 3/8" bolts and nuts that pass through the sides. We offer a complete line of accessories and connectors to aid in installation. Wall mount trays also include three 3/4" wall spacers to space the tray off the wall and aid installation on uneven surfaces.

Lengths: The trays are supplied in 10' or 12' lengths that allow 10' or 12' support spacing, when hanging tray with the supplied splice/hanger connector.

Widths: All widths are measured to the inside of the rungs, except for bottom rung mount 6", 9", and 12" wide trays. These widths include an additional 1-1/2" for the spine width.

(Example: a 6" wide bottom mount width is 7-1/2")

HUSKY CENTRAY NEMA LOAD AND DEFLECTION TABLES

TOP MOUNT RUNG NEMA 12C

Support Span	5 foot		6 foot		8 foot		10 foot		12 foot	
	Load	Defl.	Load	Defl.	Load	Defl.	Load	Defl.	Load	Defl.
	576	0.332	400	0.478	225	0.85	144	1.328	100	1.913
Meets CSA Class D (179 kg per meter on a 3 meter span) Exceeds CSA Class C (97 kg per meter on a 3 meter span) 1.5 Safety Factor										

BOTTOM MOUNT RUNG NEMA 12B

Support Span	5 foot		6 foot		8 foot		10 foot		12 foot	
	Load	Defl.	Load	Defl.	Load	Defl.	Load	Defl.	Load	Defl.
	455	0.262	316	0.378	178	0.672	114	1.049	79	1.511
Exceeds CSA Class C (97 kg per meter on a 3 meter span) 1.5 Safety Factor										

Note: Wall mount trays require mounting on the ends and in the middle of 10' or 12' sections to meet loading requirements.

Advantages of Husky Centray Support Systems

- ◆ Cable tray sections are securely joined by only two bolts or an EZ-Clip, which greatly reduces installation costs.
- ◆ Reduced cable installation headaches, as the cable tray is easily accessed from the side. Cable loading, inspection and retrofit is simplified.
- ◆ For lightweight reliability, Husky Centray systems are made from corrosion-resistant, high-strength aluminum.
- ◆ EZ-Clip speeds installation time and minimizes hardware.
- ◆ Over 50% less support hardware than standard cable trays.
- ◆ Standard cable tray fittings are no longer needed for elbows, tees and crosses.
- ◆ For safety and reliability, rungs are firmly attached by the four-point staking method.
- ◆ All rungs have smooth, chamfered ends.



Top and bottom rung center-supported cable tray and wall rack are CSA certified. (LR 107538)



Top rung Husky Centray meets NEMA Load Class 12C and bottom rung Husky Centray meets NEMA Load Class 12B, in accordance with NEMA Standard VE-1.



Husky Centray systems are classified by Underwriters Laboratories as a grounding means.



Top Rung

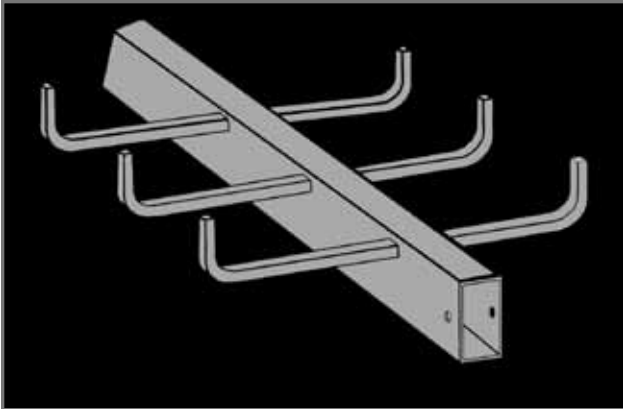

Dual-Width Rung

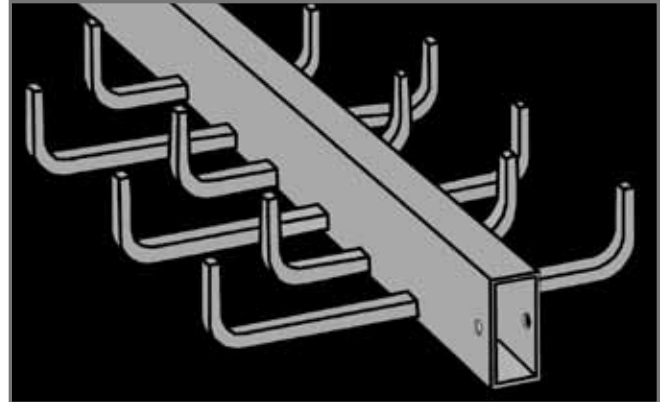

Bottom Rung

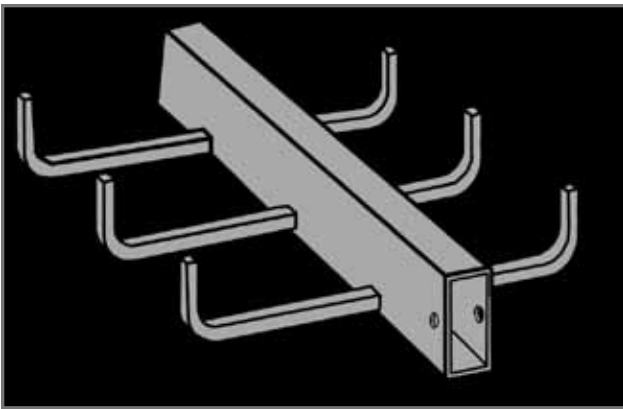

Wall Rack

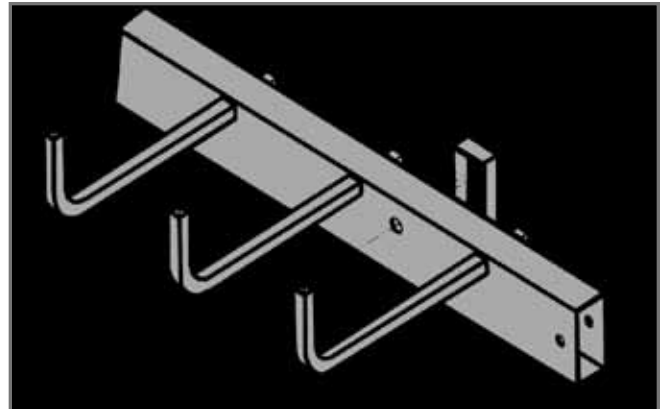

15-CENTER RAIL

Safe, Secure Rung Attachment

Husky Centray rungs come attached transversely through either the top or bottom of the center tubular rail. Each rung is securely staked to the center rail in four places. This provides additional strength and rigidity for reliable cable support. The chances for damaging and loosening rungs during transportation and cable installation are significantly reduced with this safe, reliable and secure method of rung attachment.

Husky Centray rung tips are chamfered to provide a smooth end and limit possible damage to cables or personnel.

4-Point Staking

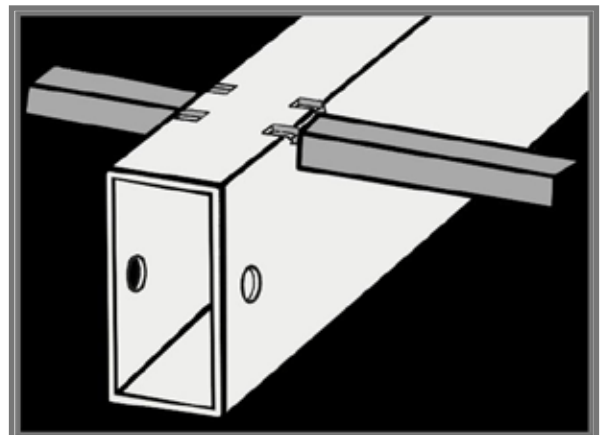

INTRODUCTION

For an integrated wire management system, Husky Centray simplifies the support and routing of power and telecom / teledata cabling. A single hanger rod is used at each support point. This makes installation easier by reducing support requirements and eliminating the need to pull cable through the trapeze supports. With Husky Centray, cables can be laid in on both sides.

Easy Support and Coupling

Both the support and connection of Husky Centray sections is accomplished by a single splice coupling designed to save time. If additional support is needed beyond the 12 foot or 3 meter intervals, simply use the intermediate support hanger.

Note: Splice coupling and spine attachment hardware are included with each straight section.

Step 1

Insert 1/2" rod into coupling

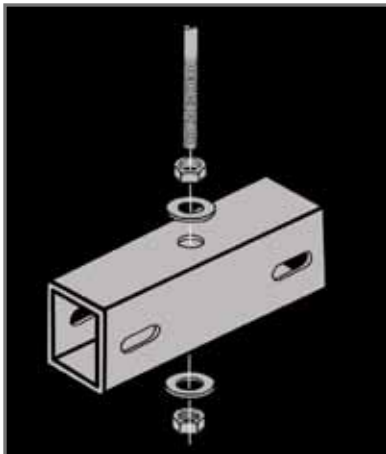

Step 2

Attach center section to coupling

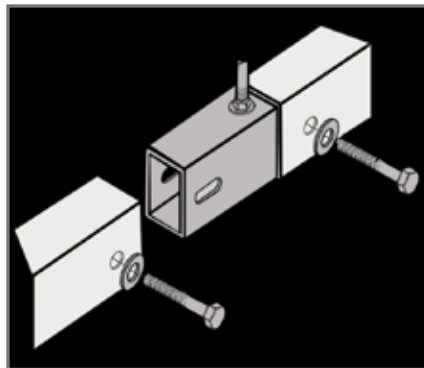

Step 3

Slide together and tighten

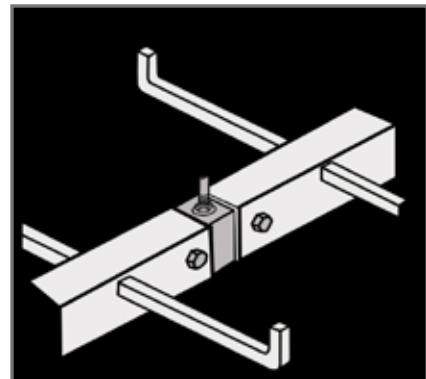

Save time and money:

No elbow fittings required.

50% less labor.

75% less components and hardware than traditional systems.

All rungs come firmly pre-attached.

Reduce Fittings with Just Four Connectors Save Time with the EZ-Clip

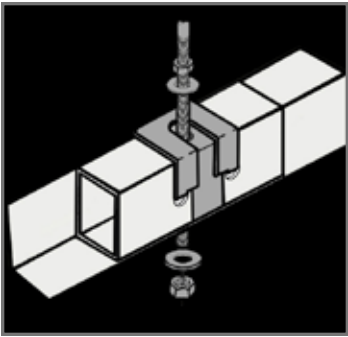

Straight Splice Connector
w/EZ-Clip

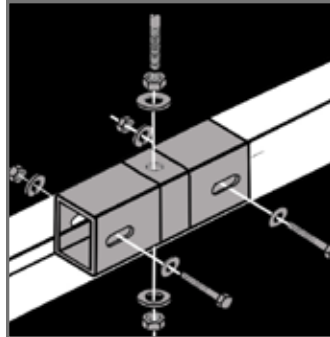

Straight Splice Connector
w/Bolts

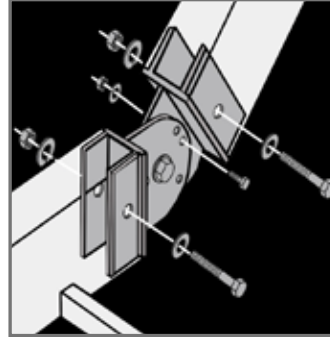

Vertical Hinge
Connector

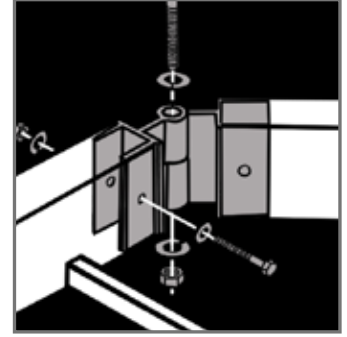

Horizontal Hinge
Connector

This exclusive new method allows for easy coupling of Husky Centray sections, without the nuts and bolts.

Step 1

Insert 1/2" rod into coupling

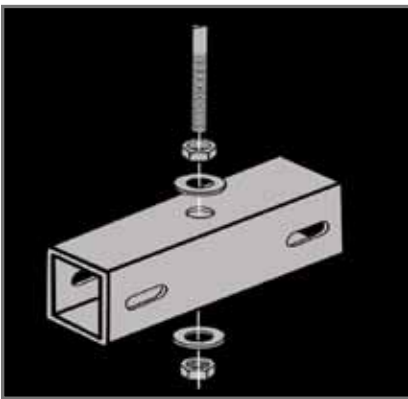

Step 2

Slide sections together and place EZ-Clip around threaded rod

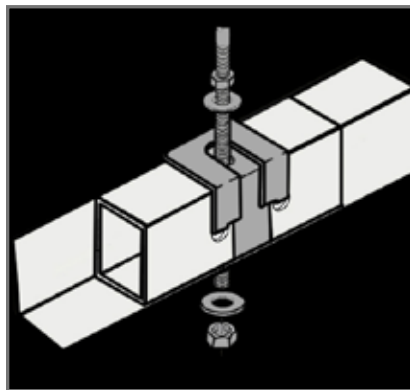

Step 3

Clip in place & tighten

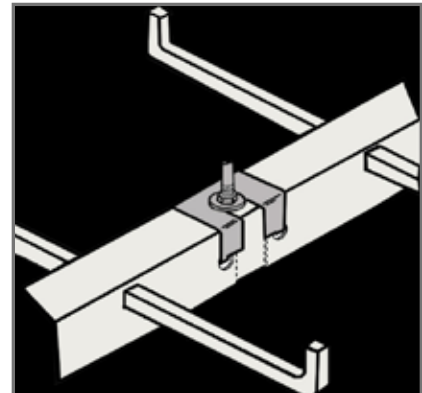

EZ-Clip can be used to attach to existing threaded rod due to its unique wrap-around design.

Top Rung Numbering System

A12T4-12-144					
A	12	T	4-	12-	144
Material	Rung Spacing	Style of Tray	Depth	Width	Length
Material: A=Aluminum	Rung Spacing: 3" 6" 9" 12" 18"	Tray Types: T=Top Mount Rung L=Bottom Mount Rung WT=Wall Mount Top Rung Single Tier WL=Wall Mount Bottom Rung Single Tier DT=Wall Mount Top Rung Double Tier	Depth: 3" 4" 6"	Width: 6" 9" 12" 18" 24"	Lengths: 144" (12 ft.) 120" (10 ft.)

Other Technical Data

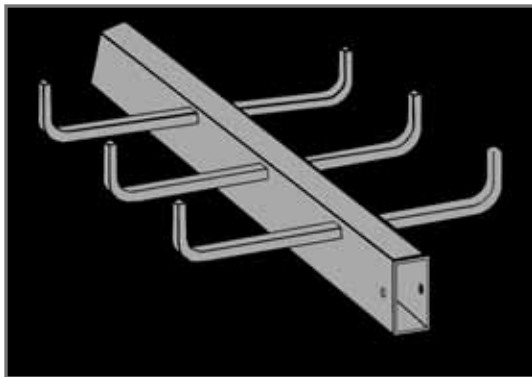

15-CENTER RAIL

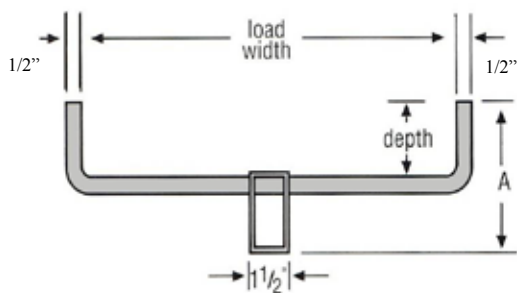

Husky Centray Load Depth (in.)	A Overall Height: Top Rung Design	
3"	5-7/8"	
4"	6-7/8"	
6"	8-7/8"	
	LOAD WIDTH	OUTSIDE WIDTH OVERALL
Husky Centray Width (in.)	Top Rung	Top Rung
6"	6"	7"
9"	9"	10"
12"	12"	13"
18"	18"	19"
24"	24"	25"



Bottom Rung Numbering System

A12L4-12-144					
A	12	L	4-	12-	144
Material	Rung Spacing	Style of Tray	Depth	Width	Length
Material: A=Aluminum	Rung Spacing: 3" 6" 9" 12" 18"	Tray Types: T=Top Mount Rung L=Bottom Mount Rung WT=Wall Mount Top Rung Single Tier WL=Wall Mount Bottom Rung Single Tier DT=Wall Mount Top Rung Double Tier	Depth: 3" 4" 6"	Width: 6" 9" 12" 18" 24"	Lengths: 144" (12 ft.) 120" (10 ft.)

Other Technical Data

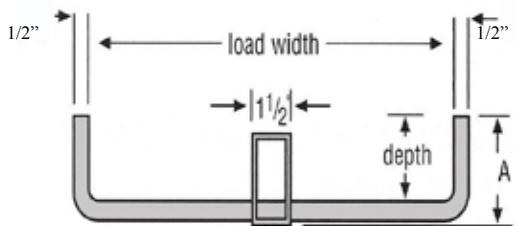
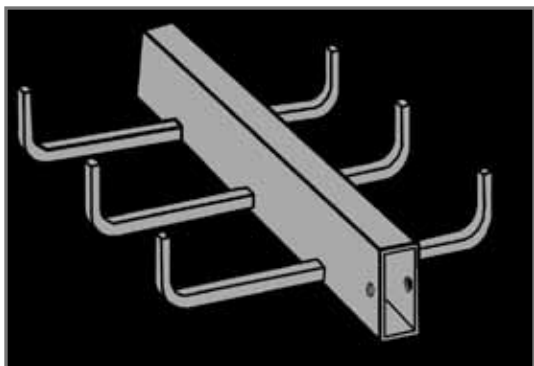

Husky Centray Load Depth (in.)	A Overall Height: Bottom Rung Design
3"	3-1/8"
4"	4-1/8"
6"	6-1/8"

	LOAD WIDTH	OUTSIDE WIDTH OVERALL
Husky Centray Width (in.)	Bottom Rung	Bottom Rung
6"	7-1/2"	8-1/2"
9"	10-1/2"	11-1/2"
12"	13-1/2"	14-1/2"
18"	18"	19"
24"	24"	25"

15-CENTER RAIL

Dual Width Rung Numbering System

A12L4-6/12-144					
A	12	L	4-	6/12-	144
Material	Rung Spacing	Style of Tray	Depth	Width	Length
Material: A=Aluminum	Rung Spacing: 3" 6" 9" 12" 18"	Tray Types: T=Top Mount Rung L=Bottom Mount Rung (Dual Width) WT=Wall Mount Top Rung Single Tier WL=Wall Mount Bottom Rung Single Tier DT=Wall Mount Top Rung Double Tier	Depth: 3" 4" 6"	Width: 6" 9" 12" 18" 24"	Lengths: 144" (12 ft.) 120" (10 ft.)

Other Technical Data

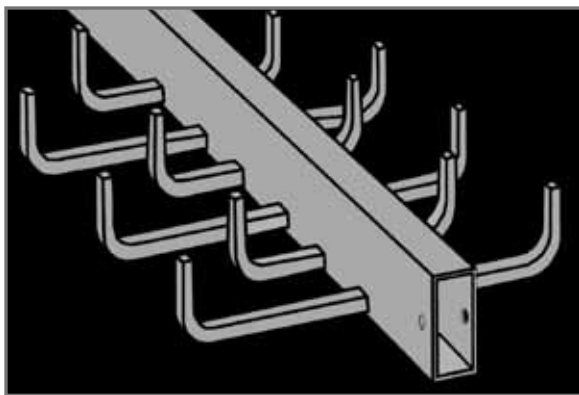

Unique dual-width rungs provide four separate cable compartments without dividers.

Dual-width rung catalog numbers utilize our standard format, shown above, except both widths are shown. (see yellow box above)

Patent Pending



Wall Rack Numbering System

A12WL4-6-144					
A	12	WL	4-	6/12-	144
Material	Rung Spacing	Style of Tray	Depth	Width	Length
Material: A=Aluminum	Rung Spacing: 3" 6" 9" 12" 18"	Tray Types: T=Top Mount Rung L=Bottom Mount Rung (Dual Width) WT=Wall Mount Top Rung Single Tier WL=Wall Mount Bottom Rung Single Tier DT=Wall Mount Top Rung Double Tier	Depth: 3" 4" 6" (4" maximum for bottom rung)	Width: 3" 6" 9" 12"	Lengths: 144" (12 ft.) 120" (10 ft.)

Other Technical Data

- ◆ Available in Single Tier or Double Tier. Only difference in part numbers is that you put both widths for the Double Tier tray (yellow box above).
- ◆ Mount directly to the wall with 3 bolts for each 12' or 3 meter section.
- ◆ Three 3/4" spacers are provided with each section.

Single Tier

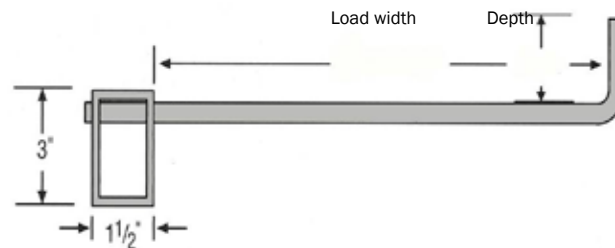
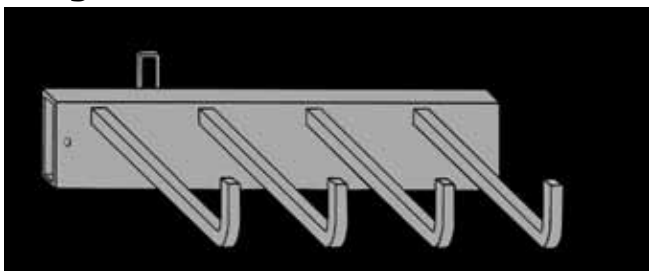

Double Tier

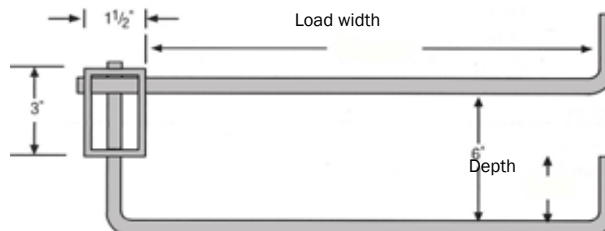
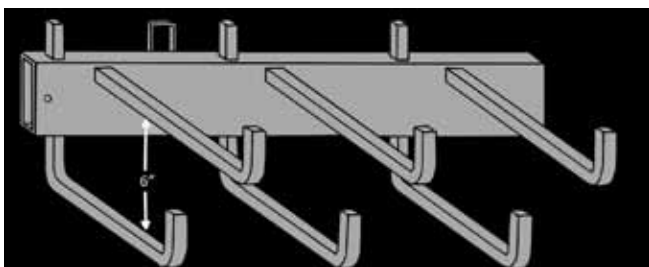

15-CENTER RAIL

Connectors and Couplings

Horizontal Tee / 90° Connector

	Bottom Rung Part #	Top Rung Part #
6"	ASP-TL-3	ASP-TT-3
9"	ASP-TL-4-1/2	ASP-TT-4-1/2
12"	ASP-TL-6	ASP-TT-6
18"	ASP-TL-9	ASP-TT-9
24"	ASP-TL-12	ASP-TT-12
	Bottom Mounted Wall Rack Part #	Top Mounted Wall Rack Part #
3"	ASP-TL-3	ASP-TT-3
6"	ASP-TL-6	ASP-TT-6
9"	ASP-TL-9	ASP-TT-9
12"	ASP-TL-12	ASP-TT-12

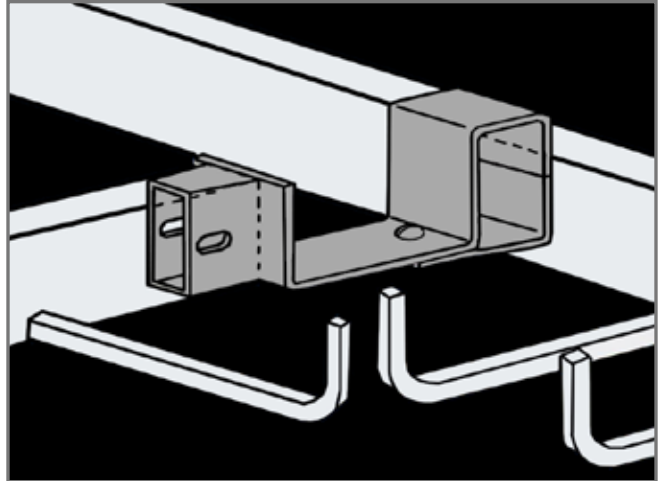

Horizontal Cross Coupling

	Bottom Rung Part #	Top Rung Part #
6"	ASP-XL-3	ASP-XT-3
9"	ASP-XL-4-1/2	ASP-XT-4-1/2
12"	ASP-XL-6	ASP-XT-6
18"	ASP-XL-9	ASP-XT-9
24"	ASP-XL-12	ASP-XT-12

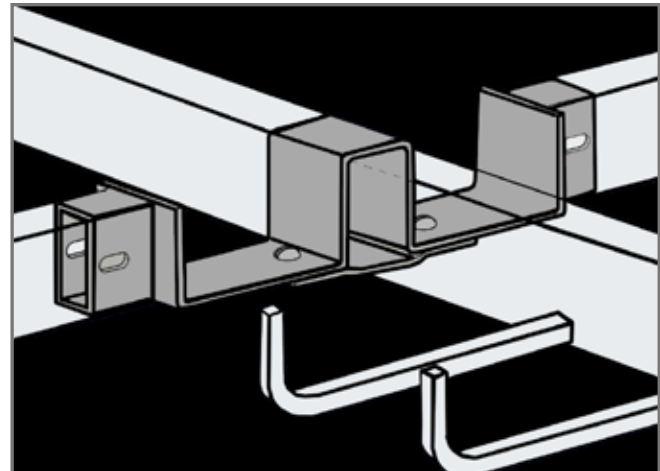

Vertical Tee / 90° Connector

Part #
ASP-VT

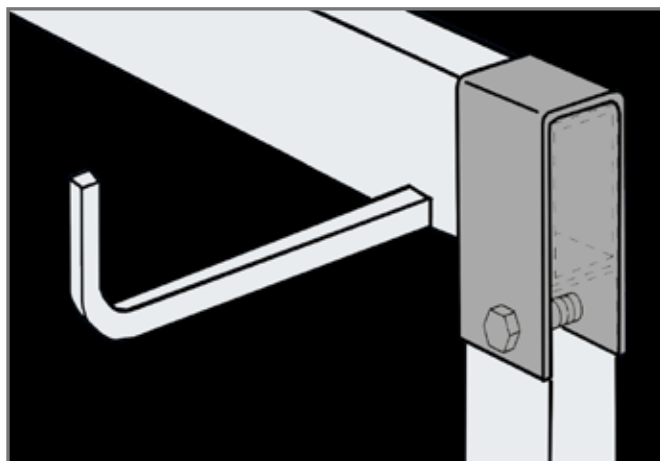

15-CENTER RAIL

Connectors and Couplings

Eliminate the need for fittings with these versatile connectors:

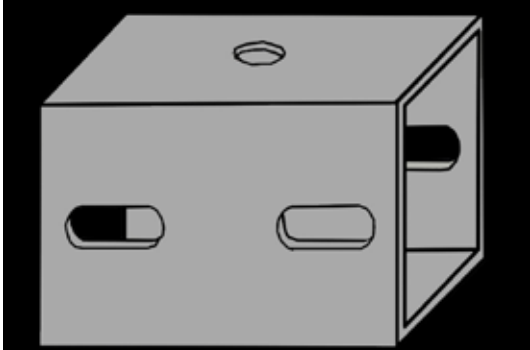

Splice/Hanger Coupling
Part #ASP-CR-B (hardware incl.)

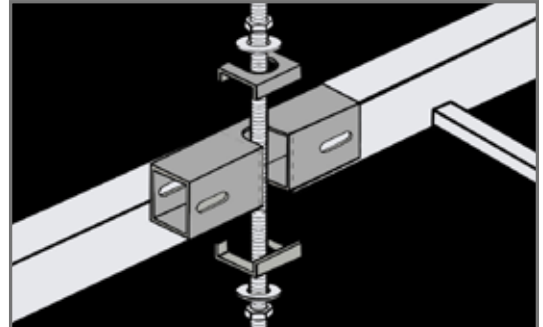

Split Splice/Hanger Coupling
Part #ASP-SPLIT (hardware incl.)

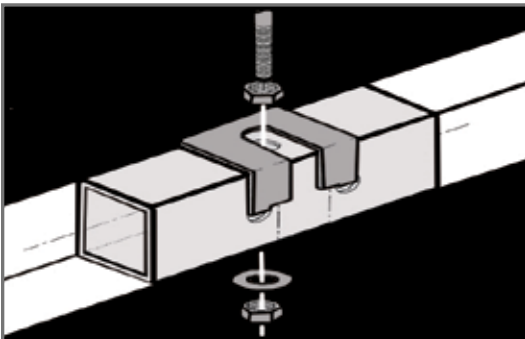

Splice/Hanger Coupling with EZ-Clip (hardware incl.)
Part #ASP-CR-EZ

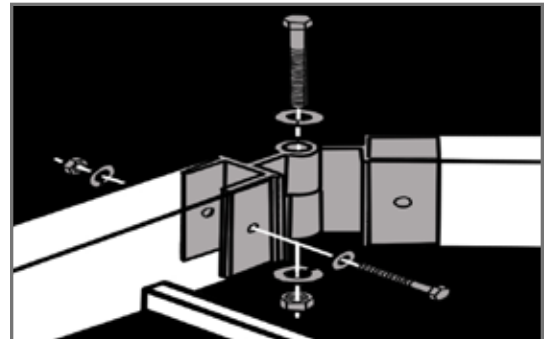

Horizontal Hinge Connector
Part #AFS-HCR (hardware incl.)

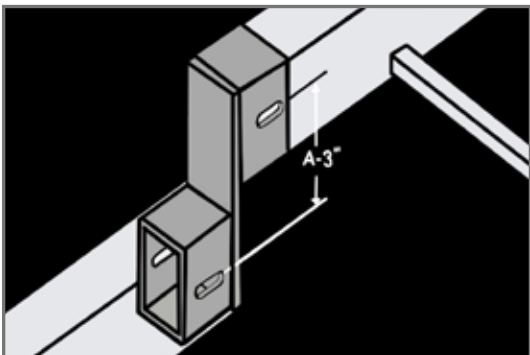

Offset Vertical Coupling
Part #ASP-VOFF-3 (hardware incl.)

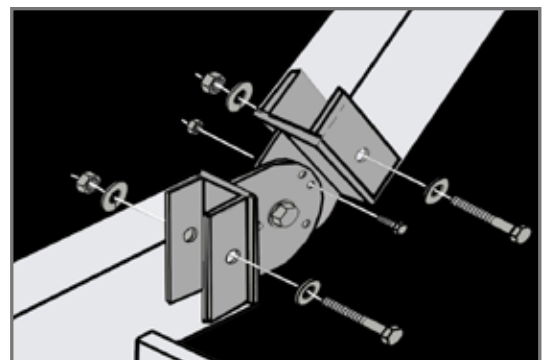

Vertical Hinge Connector
Part #AFS-VCR (hardware incl.)

15-CENTER RAIL

Accessories

Box Connector

ABC-(T)-W-D			
ABC-	(T)-	W-	D
Box Connector	Tray System	Width	Depth

Box Connector Accessory

For Cable Tray
 T = Top Mount
 L = Bottom Mount
For Wall Rack
 TR = Top Mount Right Hand
 TL = Top Mount Left Hand
 LR = Bottom Mount Right Hand
 LL = Bottom Mount Left Hand

Width:
 3"
 6"
 9"
 12"
 18"
 24"

Depth:
 3"
 4"
 6"

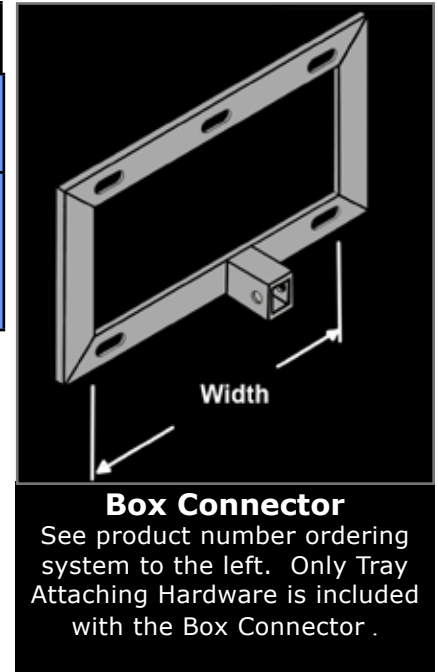

15-CENTER RAIL

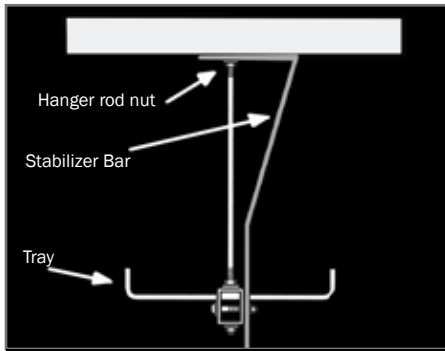

Stabilizer Bar
Part #STAB-(L)
 L=length in 6" increments from 1ft.—6ft. (Example: STAB-1-1/2)
 Stiffener bar is used to control eccentric loading.

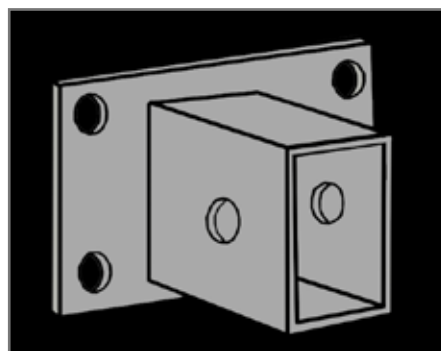

Wall Mount
Part #ASP-WALL
 This connector allows for a sturdy connection for short wall-to-wall runs. Tray attaching hardware only included.



Rail End Cap
Part #AEP-CR
 Simple one nut and bolt installation to close up end of spine. Hardware is included.



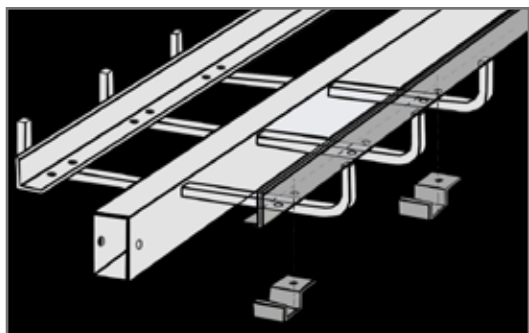

Barrier Strip

3"	Part #
4"	A3S-(L)-CR
6"	A4S-(L)-CR
	A6S-(L)-CR

Fixing clamp and screws included.

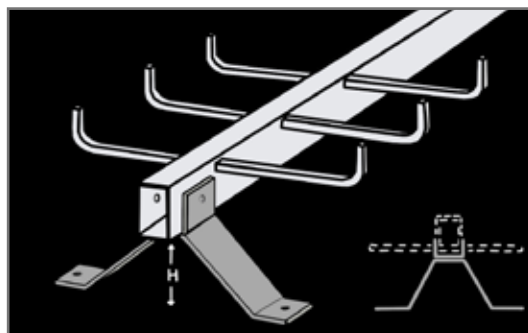

Universal Floor Support
Part # FLOOR-U

For support of both top and bottom rung designs under raised floors. Standard height is 4".

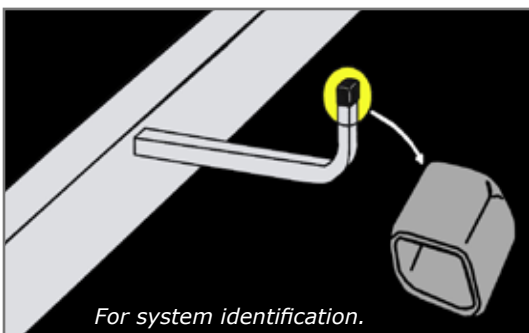

For system identification.

Rung Caps

Red	Part #
Black	RCAP-Red
Blue	RCAP-Black
Orange	RCAP-Blue
	RCAP-Orange

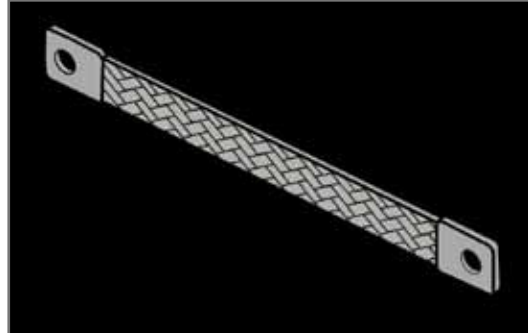

Grounding Strap
600 Amp Rating
1000 Amp Rating

Part #
AFS-CT-600-CR
AFS-CT-1000-CR

Tin plated braided copper. Standard size is 12" Long.

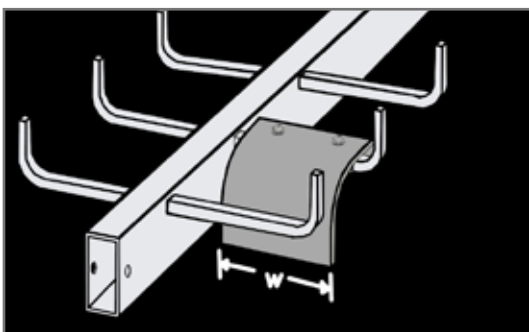

<u>Bottom Rung</u>	<u>Top Rung</u>	<u>Wall Mount</u>	<u>Size</u>
AVD-225	AVD-150	AVD-525	3"
AVD-375	AVD-300	AVD-825	6"
AVD-525	AVD-450	AVD-1125	9"
AVD-750	AVD-750	--	12"
AVD-1050	AVD-1050	--	18"
			24"

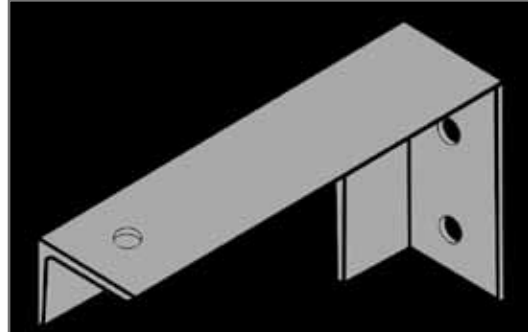

Wall Bracket

6" Wide	Part #
9" Wide	WBK-6
12" Wide	WBK-7-1/2
18" Wide	WBK-9
24" Wide	WBK-12
	WBK-15

Rugged construction with the ability to hang tray without any special clamps makes this bracket an efficient and economical device.

15-CENTER RAIL

Blind End

AEP-(T)-W-D			
AEP-	(T)-	W-	D
Blind End	Tray System	Width	Depth
Blind End	For Cable Tray T = Top Mount L = Bottom Mount For Wall Rack TR = Top Mount Right Hand TL = Top Mount Left Hand LR = Bottom Mount Right Hand LL = Bottom Mount Left Hand	Width: 3" 6" 9" 12" 18" 24"	Depth: 3" 4" 6"

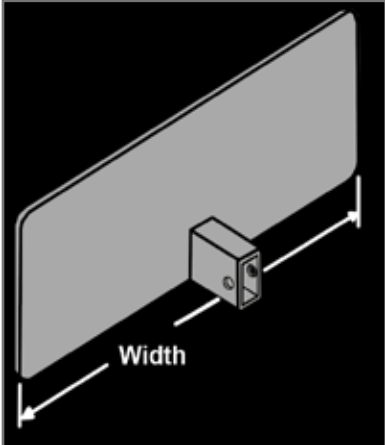

Blind End
 See product number ordering system to the left. Simple one nut and bolt installation. Hardware is included.

Intermediate Support Hanger

	Part #
Alum	AHC-CR
Steel	SHC-CR

Used to support Husky Centray in between splices.

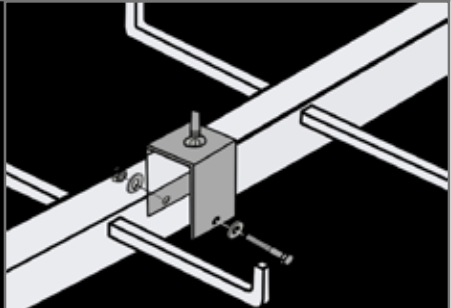

Clevis Support Hanger

	Part #
Alum	AHC-SJCR
Steel	SHC-SJCR

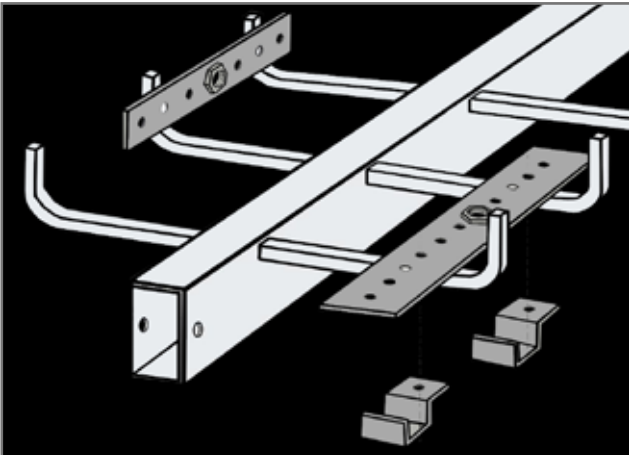
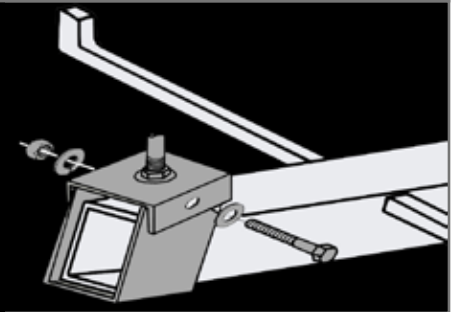

Conduit Size	Part #
1/2"	CBD1/2-(RS)
3/4"	CBD3/4-(RS)
1"	CBD1-(RS)
1-1/4"	CBD1-1/4-(RS)
1-1/2"	CBD1-1/2-(RS)
2"	CBD2-(RS)

(RS = rung spacing)

Mounting hardware is included.
 Example of Part #: CBD-1/2-6=1/2" conduit mounted to Husky Centray with a 6" rung spacing.

15-CENTER RAIL

Covers

Solid Top Cover

Standard Length is 12ft / 3 meters

Part #

Top Mounted Rung **CACTF-(W)-144 or 120**

Bottom Mounted Rung **CACLF-(W)-144 or 120**
(W = insert width)

Available Widths

6", 7-1/2", 9", 10-1/2", 12", 13-1/2", 18" and 24"

Note: Notch permits cover to slide between the support nut and washers for secure attachment. One sheet metal connector is supplied with each insert.

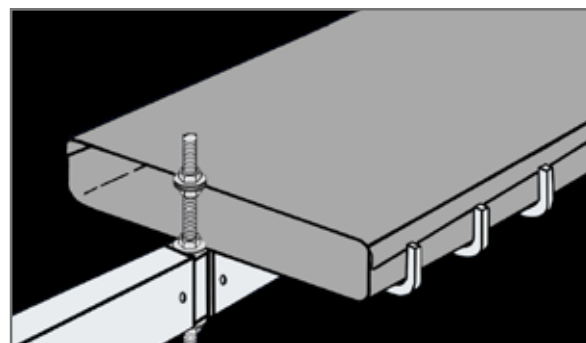
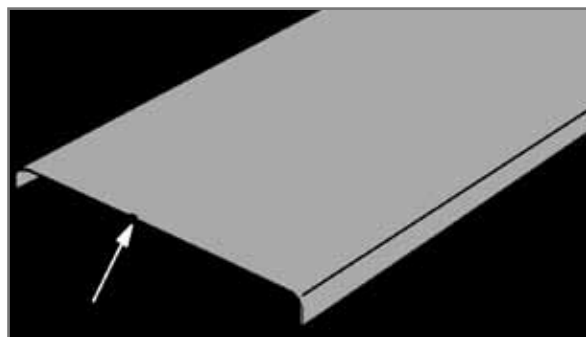

Solid Bottom Inserts

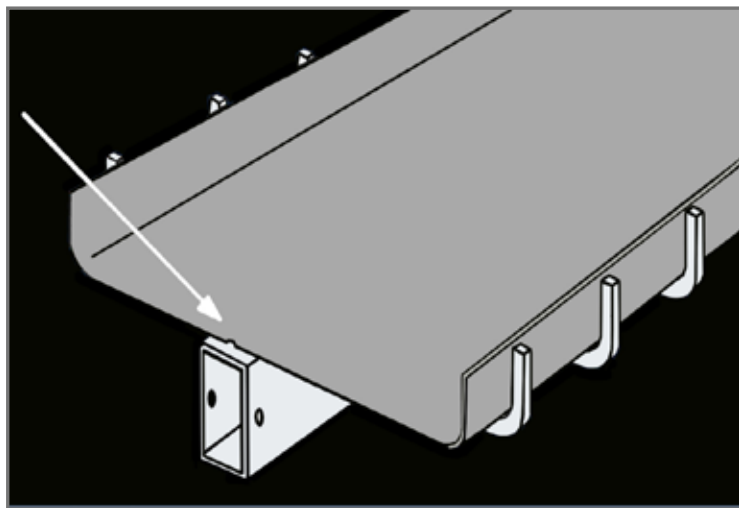

Full Width Top Rung Inserts

Part #AST(D)-(W)-144(120)
(D) Depth = 3", 4", 6"
(W) Width = 6", 9", 12", 18", 24"

Bottom Rung Inserts (order 2 pcs.)

Part #ASL(D)-(W)-144(120)
(D) Depth = 3", 4", 6"
(W) Width = 3", 4-1/2", 6, 8-1/4", 11-13/16"
-144=12' -120=10'

Tray Width	Insert Width	Part #
24"	11-3/16"	ASL(D)-11-1/4-144
18"	8-1/4"	ASL(D)-8-1/4-144
12"	5-15/16"	ASL(D)-6-144
9"	4-7/16"	ASL(D)-4-1/2-144
6"	2-15/16"	ASL(D)-3-144

Wall Mount Inserts

Part #ASWL(D)-(W)-144(120)
(D) Depth = 3", 4", 6"
-144=12' -120=10'

Tray Width	Insert Width	Part #
12"	11-15/16"	ASWL(D)-12-144
9"	8-15/16"	ASWL(D)-9-144
6"	5-15/16"	ASWL(D)-6-144
3"	2-15/16"	ASWL(D)-3-144

15-CENTER RAIL